

D3POC0208

STATE OF NORTH CAROLINA
DEPARTMENT OF TRANSPORTATION
HIGHWAY DIVISION 3

SMALL BUSINESS ENTERPRISE PROPOSAL

DATE AND TIME OF BID OPENING: June 20, 2024 AT 2:00 PM

CONTRACT ID: D3POC0208

WBS ELEMENT NO.: ON CALL - VARIOUS

FEDERAL AID NO.: STATE FUNDED

COUNTY: Brunswick, Duplin, New Hanover, Onslow, Pender, and Sampson
Counties

TIP NO.: N/A

MILES: VARIOUS MILES

ROUTE NO.: VARIOUS ROUTES THROUGHOUT DIVISION 3

LOCATION: VARIOUS LOCATIONS

TYPE OF WORK: ON CALL LITTER PICKUP - SBE

NOTICE:

UNDER THE PROVISIONS OF THIS PROGRAM, A N.C. GENERAL CONTRACTOR'S LICENSE IS NOT REQUIRED AND CONTRACT PAYMENT AND CONTRACT PERFORMANCE BONDS IS NOT REQUIRED. BIDDERS SHALL ALSO COMPLY WITH ALL OTHER APPLICABLE LAWS, INCLUDING BUT NOT LIMITED TO, THOSE REGULATING THE PRACTICES OF ELECTRICAL, PLUMBING, HEATING AND AIR CONDITIONING AND REFRIGERATION CONTRACTING AS CONTAINED IN CHAPTER 87 OF THE GENERAL STATUTES OF NORTH CAROLINA.

THIS IS A ROADWAY PROJECT.

BID BOND IS NOT REQUIRED.

NAME OF BIDDER

ADDRESS OF BIDDER

**PROPOSAL FOR THE CONSTRUCTION OF
CONTRACT No. D3POC0208 IN Brunswick, Duplin, New Hanover, Onslow, Pender and Sampson Counties,
NORTH CAROLINA
DEPARTMENT OF TRANSPORTATION,
RALEIGH, NORTH CAROLINA**

The Bidder has carefully examined the location of the proposed work to be known as Contract No. **D3POC0208**; has carefully examined the plans and specifications, which are acknowledged to be part of the proposal, the special provisions, the proposal, the form of contract; and thoroughly understands the stipulations, requirements and provisions. The undersigned bidder agrees to be bound upon his execution of the bid and subsequent award to him by the Department of Transportation in accordance with this proposal. Payment and performance bonds are not required on this project. The undersigned Bidder further agrees to provide all necessary machinery, tools, labor, and other means of construction; and to do all the work and to furnish all materials, except as otherwise noted, necessary to perform and complete the said contract in accordance with the *2024 Standard Specifications for Roads and Structures* by the dates(s) specified in the Project Special Provisions and in accordance with the requirements of the Engineer, and at the unit or lump sum prices, as the case may be, for the various items given on the sheets contained herein.

The Bidder shall provide and furnish all the materials, machinery, implements, appliances and tools, and perform the work and required labor to construct and complete Contract No. **D3POC0208** in **Brunswick, Duplin, New Hanover, Onslow, Pender and Sampson Counties**, for the unit or lump sum prices, as the case may be, bid by the Bidder in his bid and according to the proposal, plans, and specifications prepared by said Department, which proposal, plans, and specifications show the details covering this project, and hereby become a part of this contract.

The published volume entitled *North Carolina Department of Transportation, Raleigh, Standard Specifications for Roads and Structures, January 2024* with all amendments and supplements thereto, is by reference incorporated into and made a part of this contract; that, except as herein modified, all the construction and work included in this contract is to be done in accordance with the specifications contained in said volume, and amendments and supplements thereto, under the direction of the Engineer.

If the proposal is accepted and the award is made, the contract is valid only when signed either by the Contract Officer or such other person as may be designated by the Secretary to sign for the Department of Transportation. The conditions and provisions herein cannot be changed except over the signature of the said Contract Officer or Division Engineer.

The quantities shown in the itemized proposal for the project are considered to be approximate only and are given as the basis for comparison of bids. The Department of Transportation may increase or decrease the quantity of any item or portion of the work as may be deemed necessary or expedient.

An increase or decrease in the quantity of an item will not be regarded as sufficient ground for an increase or decrease in the unit prices, nor in the time allowed for the completion of the work, except as provided for the contract.

TABLE OF CONTENTS

COVER SHEET
PROPOSAL SHEET

PROJECT SPECIAL PROVISIONS

GENERAL G-1
INTERESTED PARTIES LIST NOT REQUIRED: G-3
CONTRACT TIME FOR ID/IQ:..... G-3
NON-EXCLUSIVE CONTRACT:..... G-4
WORK ORDER ASSIGNMENT (MULTIPLE AWARDS) FOR ID/IQ: G-4
BONDING REQUIREMENTS FOR ID/IQ: G-4
MOBILIZATION AND LIQUIDATED DAMAGES FOR ID/IQ: G-5
EMERGENCY MOBILIZATION FOR ID/IQ: G-6
RENEWAL OF CONTRACT (CPI PRICE ADJUSTMENT) FOR ID/IQ: G-6
DISPUTE RESOLUTION PROCESS FOR ID/IQ: G-7
INTERMEDIATE CONTRACT TIME NUMBER 1 AND LIQUIDATED DAMAGES: G-7
INTERMEDIATE CONTRACT TIME NUMBER 2 AND LIQUIDATED DAMAGES: G-8
INTERMEDIATE CONTRACT TIME NUMBER 3 AND LIQUIDATED DAMAGES: G-9
INTERMEDIATE CONTRACT TIME NUMBER 4 AND LIQUIDATED DAMAGES:G-10
NO MAJOR CONTRACT ITEMS:..... G-11
NO SPECIALTY ITEMS: G-11
FUEL PRICE ADJUSTMENT PAPER BID: G-11
SCHEDULE OF ESTIMATED COMPLETION PROGRESS:..... G-13
SMALL BUSINESS ENTERPRISE (MULTI-YEAR MAINTENANCE CONTRACTS): ... G-13
RESTRICTIONS ON ITS EQUIPMENT AND SERVICES:..... G-13
USE OF UNMANNED AIRCRAFT SYSTEM (UAS): G-13
EQUIPMENT IDLING GUIDELINES:..... G-14
OUTSOURCING OUTSIDE THE USA: G-14

ROADWAY.....R-1

STANDARD SPECIAL PROVISIONS

AVAILABILITY OF FUNDS – TERMINATION OF CONTRACTS.....SSP-1
ERRATA.....SSP-2
PLANT AND PEST QUARANTINESSSP-3
MINIMUM WAGESSSP-4
TITLE VI AND NONDISCRIMINATION:SSP-5
ON-THE-JOB TRAINING.....SSP-14

UNIT PROJECT SPECIAL PROVISIONS

TRAFFIC CONTROL..... TC-1

SIGNATURE SHEETS AND FORMS S-1
BID/PAY ITEM SHEETS..... T-1

INSTRUCTIONS TO BIDDERS

PLEASE READ ALL INSTRUCTIONS CAREFULLY BEFORE PREPARING AND SUBMITTING YOUR BID.

All bids shall be prepared and submitted in accordance with the following requirements. Failure to comply with any requirement may cause the bid to be considered irregular and may be grounds for rejection of the bid.

TRADITIONAL PAPER BIDS:

1. Download the entire proposal from the Connect NCDOT website and return the entire proposal with your bid.
2. In accordance with Article 102-3 of the *Standard Specifications*, registration on the Interested Parties List is required unless SP1 G02 Interested Parties List Not Required provision is included in the proposal.
3. All entries on the itemized proposal sheet (bid form) shall be written in ink or typed.
4. The Bidder shall submit a unit price for every item on the itemized proposal sheet. The unit prices for the various contract items shall be written in figures. Unit prices shall be rounded off by the Bidder to contain no more than FOUR decimal places.
5. An amount bid shall be entered on the itemized proposal sheet for every item. The amount bid for each item shall be determined by multiplying each unit bid by the quantity for that item, and shall be written in figures in the "Amount" column of the form.
6. The total amount bid shall be written in figures in the proper place on the bid form. The total amount bid shall be determined by adding the amounts bid for each item.
7. Changes to any entry shall be made by marking through the entry in ink and making the correct entry adjacent thereto in ink. A representative of the Bidder shall initial the change in ink. Do not use correction fluid, correction tape or similar product to make corrections.
8. The bid shall be properly executed on the included **Execution of Bid – Non-collusion, Debarment and Gift Ban Certification** form. All bids shall show the following information:
 - a. Name of corporation, partnership, Limited Liability Company, joint venture, individual or firm, submitting bid.
Corporations that have a corporate seal shall include it on the bid, otherwise write your corporations name in the seal location.
 - b. Name of individual or representative submitting bid and position or title held on behalf of the bidder.
 - c. Name, signature, and position or title of witness.
9. The bid shall not contain any unauthorized additions, deletions, or conditional bids.
10. The Bidder shall not add any provision reserving the right to accept or reject an award, or to enter into a contract pursuant to an award.
11. **THE PROPOSAL WITH THE ITEMIZED PROPOSAL SHEET ATTACHED SHALL BE PLACED IN A SEALED ENVELOPE AND SHALL BE DELIVERED TO AND RECEIVED IN THE NCDOT DIVISION OFFICE, LOCATED AT 5501 Barbados Blvd., BY 2:00 PM ON, June 20, 2024.**
12. The sealed bid must display the following statement on the front of the sealed envelope:

QUOTATION FOR – CONTRACT ID D3POC0208 – ON CALL LITTER PICKUP - SBE AT VARIOUS LOCATIONS TO BE OPENED AT 2:00 PM ON, June 20, 2024.

As well as the following information:

- a. Name of corporation, partnership, Limited Liability Company, joint venture, individual or firm, submitting bid.
- b. Name of individual or representative submitting bid and position or title held on behalf of the bidder.
- c. Address of corporation, partnership, Limited Liability Company, joint venture, individual or firm, submitting bid.

d. SAP Vendor Number of corporation, partnership, Limited Liability Company, joint venture, individual or firm, submitting bid.

e. Contractor Number, if applicable, of corporation, partnership, Limited Liability Company, joint venture, individual or firm, submitting bid.

13. If delivered by mail, the sealed envelope shall be placed in another sealed envelope and the outer envelope shall be addressed as follows:

**N. C. DEPARTMENT OF TRANSPORTATION
DIVISION OF HIGHWAYS, DIVISION 3
ATTN: Jonathan W. Mitchell
5501 Barbados Blvd.
Castle Hayne, NC 28429**

14. Questions should be emailed 7 calendar days prior to the bid opening to **Jonathan W. Mitchell** at jwmitchell1@ncdot.gov. Contact with any other NCDOT personnel concerning this project is strictly prohibited, unless otherwise noted, and may result in bids being considered non-responsive.

PROJECT SPECIAL PROVISIONS

GENERAL:

This contract is for litter/debris removal and recycling, upon request, on interstate, primary, and secondary roads and their interchanges in Brunswick, Duplin, New Hanover, Pender, Onslow, and Sampson Counties in Division 3. The notification shall be for a minimum of one half shoulder mile (may consist of more than one route within a county) of litter/debris collection with the following exceptions. Isolated Dump Sites may be required to be picked up separately outside of the notified pickup area(s). Isolated Bulk Items shall be required to be picked up separately outside of the notified pickup area(s). The Contractor is to provide all equipment, labor and material.

LITTER/DEBRIS REMOVAL AND RECYCLING

An abundance of non-organic trash in a multitude of forms is deposited daily along the roadsides of the designated highways. These conditions detract from the visual quality and/or safety of the roadside landscape.

This contract is for litter/debris removal and recycling upon request on interstate, primary and secondary roads and their interchanges within the State Maintained Highway System Right of Way in Division 3 - Brunswick, Duplin, New Hanover, Pender, Onslow, and Sampson Counties.

All items include all traffic control necessary to provide a safe work area. The work shall include the furnishing of all equipment, tools, materials, transportation and labor necessary for the successful completion of the work.

No separate payment will be made for providing, installing, and maintaining traffic control devices, etc., or for any other cost associated with maintaining the control of traffic. Traffic control will be considered incidental to the contract, and will be included in the Bid Items as listed on the Contract Bid Form.

The designated area for litter/debris removal and recycling is the entire corridor from controlled access fence to controlled access fence, or right of way width, including the median and interchange areas, to the travel lane, as directed by the Engineer, **except for along concrete barrier walls in medians. (Litter crew and vehicles are not allowed against median concrete barrier walls).** The designated area for on call litter/debris removal and recycling on shoulders is the white edge line to the This includes the mowing areas as well as non-mowing areas.

Isolated Dump Sites are defined as areas measuring less than one-tenth of a shoulder mile, with excessive litter/debris accumulation, as determined by the Engineer. These sites may or may not be within the notified pickup area(s).

Isolated Bulk Items are defined as items to be picked up separately outside of the notified pickup area(s), including Isolated Dump Sites. Isolated Bulk Items may include, but not limited to, appliances, tires, tire treads, furniture, cardboard, pallets, brick, concrete block, ladders, building materials, etc. as determined by the Engineer.

The Contractor should be prepared for removing litter/debris in roadside conditions including but not

limited to wet areas, standing water, high grass, and slopes. Contractor will not be responsible for removing litter/debris in wooded areas or back slopes unless litter is visible from the roadway and/or ramps.

The operation of litter/debris pickup shall be on foot only. Vehicles as specified herein may be used for bag pickup.

The Contractor shall provide adequate personnel and materials (litterbags) to remove litter/debris on all areas of the right-of-way or controlled access.

The operation shall include the pickup, removal and recycling of litter/debris and the disposal of same into state approved landfills and single-stream recycling facilities. Litter/debris items may consist of varied sizes of bottles, cans, paper, tires, tire pieces, lumber, vehicle parts, building supplies, metals, household furnishings, cardboard, plastics, ladders, brush and other items not considered normal to the right of way.

The Contractor shall be responsible for locating and utilizing approved local landfills and recycling facilities so as not to impede the progress of the cleanup operation.

All collected litter/debris shall be containerized immediately and kept off of the traveled portions of the roadway, shoulders, and right-of-ways (including paved shoulders) during that day's collection process. All collected litter that is small enough to be placed in a bag shall be bagged immediately. All collected litter that is too large for a bag shall be placed into a vehicle. Uncollected storage or stockpiling of litter/debris and recyclables (piles of litterbags, tires, tire debris, etc.) will not be permitted. **At no time shall bags or collected litter/debris be allowed to remain on the right of way beyond the end of the work day.**

All cost involved with the disposal of the litter/debris shall be included in the contract unit price for "Litter/Debris Removal and Recycling". Vehicles for litter/debris removal activities shall at all times be parked off the pavement as close to the right-of-way fence as possible.

The Contractor's personnel shall pickup and dispose of any litter/debris, not required to be recycled, in a landfill approved by North Carolina Division of Waste Management. Litter/debris may consist of any item not considered normal to the right-of-way. The Contractor will not be allowed to use NCDOT accounts at the landfills nor be allowed to dispose of the litter/debris in NCDOT trash containers on any NCDOT property.

The Contractor shall submit dumping ticket of the number of pounds of litter/debris not recycled to the Roadside Environmental Office with the Contractor's invoice. Clean up shall not be considered accepted by the Department until the original **DUMPING TICKET** issued to the Contractor for disposing the materials picked up during the assigned work is presented to the Department's inspector.

This contract shall be immediately terminated if the contractor is found guilty of illegal dumping. Work will be suspended if contractor is charged with illegal dumping.

The Contractor's attention is directed to North Carolina General Statute 130A-309.10 (f) though (m). Per this statute, the Contractor performing litter clean up and removal shall be required to recycle, including, but not limited to, aluminum cans, glass bottles, plastic bottles, and rubber tires collected within the right of way. In an effort to align with efforts by the Department to recycle with litter removal, the Contractor shall participate in single-stream recycling. The Contractor shall be responsible for locating and utilizing single-stream recycling facilities for disposal of recyclable litter/debris removed from the right of way as part of the work of this contract. The Contractor may recycle at any public or commercial recycling facility so long as the facility has the ability to provide

weight tickets.

Assistance in locating recycling facilities may be obtained on the following websites:

<http://portal.ncdenr.org/web/deao/mrf>,

<http://www.p2pays.org/dmrm/start.aspx>, <http://p2pays.org/localgov/ncwaste.html>.

The Contractor shall utilize blue bags, similar to those used by the Department, for the collection of recyclable materials. The Contractor will not be allowed to use NCDOT accounts at the recycling facilities nor be allowed to dispose of the litter/debris in NCDOT recycling containers on any NCDOT property.

The Contractor shall submit weight tickets of the number of pounds of each of the recycled materials listed to the Roadside Environmental Office with the Contractor's invoice. **The North Carolina Department of Transportation will require evidence of reported recycling using weight tickets from the recycling facilities.**

If the Contractor is not fulfilling the intent of the Department to participate in a recycling program it could result in termination of this contract.

The Engineer reserves the right to schedule litter/debris removal and recycling operations so as not to conflict with mowing and/or vegetation management operations. Any bags, litter, or debris that are not removed before mowing and are shredded by the mowers must still be removed.

INTERESTED PARTIES LIST NOT REQUIRED:

(6-21-22)(Rev. 2-20-24)

102

SP1 G02

Revise the *Standard Specifications* as follows:

The *Interested Parties List* sign up process is not applicable to this contract.

Page 1-13, Article 102-3 PROPOSALS AND INTERESTED PARTIES LIST, lines 12-15, delete the first paragraph.

Page 1-14, Article 102-8 PREPARATION AND SUBMISSION OF BIDS, lines 43-44, delete the first sentence of the first paragraph.

CONTRACT TIME FOR ID/IQ:

(2-15-22)

108

SP1 G11

The date of availability for this contract is **August 5, 2024**.

The completion date for this contract is **August 4, 2025**.

Except where otherwise provided by the contract, observation periods required by the contract will not be a part of the work to be completed by the completion date and/or intermediate contract times stated in the contract. The acceptable completion of the observation periods that extend beyond the final completion date shall be a part of the work covered by the performance and payment bonds.

Work shall be accomplished in a continuous manner once the contractor begins.

Any liquidated damages for this contract will be assessed per the Mobilization and Liquidated Damages provision located elsewhere in this Contract.

NON-EXCLUSIVE CONTRACT:

(6-1-15)

SPD 01-750

The Department may, as it deems to be in the best interest of the state and the Department of Transportation, execute more than one contract based on this proposal. The Contractor(s) understands and agrees, by signature on the Purchase Order Contract Bid Proposal, that this agreement does not constitute an exclusive contract. If awarded, the contracts will be executed with the lowest responsible bidders. The Department of Transportation reserves the right to make multiple awards for the services provided by this contract. Furthermore, the Department reserves the right to reject all bids received.

WORK ORDER ASSIGNMENT (MULTIPLE AWARDS) FOR ID/IQ:

(2-15-22)(Rev. 4-19-22)

SPD 01-800B

Work orders will be assigned based on the lowest work order cost for the line items and estimated quantities necessary to complete the work order. Unit prices from each awarded contractor's bid will be used to determine the lowest cost for each work order. The assigned Contractor shall respond to the work order assignment with the anticipated start date, within three working days of notification unless noted otherwise. Failure on the part of the Contractor to reply within the specified time frame may be received as a rejection of the work order. If the Contractor with the lowest work order cost cannot complete the work within the time specified in the assignment, the Engineer may contact the Contractor with the next lowest work order cost. If that Contractor can complete the work within the time specified in the assignment, then the work order will be assigned to that contractor. If not, assignment of work order will continue in order of work order cost until all awarded Contractors have had a chance to accept the terms of the assignment.

For federal ID/IQ contracts, all work orders will be assigned via the Work Order Assignment form (Form IDIQ-1MA), and the Contractor is required to formally respond in writing for federal work orders within three working days, unless noted otherwise. The Work Order Assignment form will also be used for any state ID/IQ contract in which the estimated work order cost meets the threshold for Performance and Payment Bonds in accordance with the Bonding Requirements for ID/IQ provision found elsewhere in this contract. For state ID/IQ contracts in which the work order assignment doesn't meet the threshold for bonds, the Department has the option to use the Work Order Assignment Form or other methods for work order assignments as agreed upon by the Engineer and Contractor.

The Contractor shall be required to prosecute the work in a continuous and uninterrupted manner from the time they begin the work until completion and final acceptance of the work order. Multiple failures of the Contractor to mobilize and begin work on the work order within the agreed upon time frame or failure to complete the work within the given time frame may result in the Contractor being excluded from future work on this contract in accordance with the *Standard Specifications*.

BONDING REQUIREMENTS FOR ID/IQ:

(2-15-22)

SPD 01-810

For purposes of this ID/IQ contract, the following definitions apply:

Project Agreement: A transportation improvement with a defined scope of work; a written agreement between NCDOT and the Federal Government defining the extent of construction work to be undertaken in accordance with the submitted plans, specifications and estimates. Execution of the agreement prompts the authorization to proceed (construction funding).

Project: An undertaking issued to a contractor through a Work Order Assignment. The construction under a Project Agreement may be accomplished by one or more work order assignments, from one or more ID/IQ contracts. Note that for ID/IQ contracts this definition supersedes the definition in the Standard Specifications.

Award: The issuance of a signed Work Order Assignment by NCDOT shall constitute the notice of award of a project.

In accordance with North Carolina General Statute 44A-26, bonds are required on contracts awarded for any one project that exceeds \$500,000. Beyond statutory requirements, NCDOT policy requires payment and performance bonds on all projects where the engineer's estimate is \$450,000 or greater, all Asphalt Surface Treatment projects, and projects containing the 12-month guarantee provision. The limit for waiving bonds for all bridge replacement and major bridge rehabilitation projects (latex overlays, etc.) is \$300,000 based on the engineer's estimate. The decision of bonding of a work order assignment below the dollar amounts listed shall be at the discretion of the Division's evaluation of the risks associated with the project.

The need for contract payment and performance bonds will be determined at the Work Order Assignment level. The Work Order Assignment will notify the Contractor of an award of a project and if required, to provide contract payment and performance bonds per Article 103-7 of the *Standard Specifications*. The Work Order Assignment replaces the Notification of Award Letter mentioned in Article 103-4(A) of the *Standard Specifications*.

MOBILIZATION AND LIQUIDATED DAMAGES FOR ID/IQ:

(2-15-22)

SPD 01-820

The Contractor shall mobilize to each location he is required to perform work. There will be no direct pay for Mobilization as it will be incidental to the other bid items. The only exception is if there is an Emergency Mobilization provision within the contract.

The Contractor will be provided a Work Order Assignment for each project with location(s), estimated quantities, and liquidated damages unless waived by the Engineer. Notification will be verbal followed by a faxed or emailed signed Work Order Assignment. There will be no minimum quantities for any line item associated with a particular mobilization. The Contractor shall complete the work identified on each Work Order Assignment.

The Contractor shall mobilize and complete the work within the time specified on the Work Order Assignment. Failure to complete the work by the completion date may result in the application of liquidated damages. Liquidated damage amounts will be based on the work order estimate and the liquidated damage table below.

Work Order Value	Liquidated Damages (per calendar day)
\$0 - \$100K	\$100.00
\$100K - \$200K	\$250.00
\$200K - \$300K	\$500.00
\$300K - \$500K	\$600.00
\$500K - \$1M	\$700.00
\$1M - \$2M	\$850.00

EMERGENCY MOBILIZATION FOR ID/IQ:

(2-15-22)

SPD 01-830

The Contractor shall arrive on site within **Forty Eight (48)** hours of notification. Compensation will be in addition to the specific line items in the contract. *Emergency Mobilization* will be paid for at the contract unit price per each. Failure to respond within the time frame will result in nonpayment of this item.

Payment will be made under:

Pay Item

Emergency Mobilization

Pay Unit

Each

RENEWAL OF CONTRACT (CPI PRICE ADJUSTMENT) FOR ID/IQ:

(2-15-22)(Rev. 9-19-23)

SPD 01-840

The Contractor shall submit a bid for one year. At the option of the Department, this contract may be extended for **Two (2)** additional periods of one year each (maximum (3) three years total). Each year shall have a limit of **One Million Dollars (\$1,000,000)**.

The compensation payable to the contractor shall be fixed for the first twelve months of this contract. However, upon an application of renewal of the contract, or thirty days prior to the end of each contract period, the renewal contract may be adjusted to reflect the adjustment in the

Consumer Price Index over the latest twelve month period as published by the US Bureau of Labor and Statistics at <http://www.bls.gov/cpi> to be applied to new work order assignments. The Consumer Price Index for All Urban Consumers (CPI-U), US City Average, All Items, 1982-84=100, not seasonally adjusted will be used. If the amount of the requested adjustment is more than ten percent, the Department of Transportation reserves the right to cancel this contract.

CPI adjustment values can be determined using the calculator on the NCDOT Construction website.

This price escalation method will not be applied to items of work that are separately covered under commodity price escalation clauses. No other changes in the terms, conditions, etc. of this contract will be made when an extension to the contract is implemented. The Engineer will notify the Contractor in writing by **June 1st** if the contract may be extended. The Contractor must notify the Engineer in writing by **June 15th** of his acceptance or rejection of this offer. Failure on the part of the Contractor to reply will be received as a rejection of contract extension.

DISPUTE RESOLUTION PROCESS FOR ID/IQ:

(2-15-22)(Rev. 1-16-24)

SPD 01-850

If a question should arise on the contract or assignment of a work order, the contractor should notify the Engineer noted on the assignment documentation or the Division Engineer within 48 hours after the scheduled time of bid opening or work order assignment. The following should be included in the notification if applicable:

- (A) the contract for which bids were solicited;
- (B) the particular law, regulation, or contract specification violated;
- (C) a detailed description of the alleged violation; and
- (D) any other information deemed to be relevant.

Once the initial evaluation has been completed, the contractor may be asked to attend a meeting for further discussion and clarification.

Once a determination has been made, the contractor will be notified of the decision by the Division Engineer. If the decision does not meet the satisfaction of the contractor, they have 24 hours from the Division Engineer's notification to elevate the dispute to the Chief Engineer. The Chief Engineer will make the final decision and will not be subject to further review by NCDOT.

INTERMEDIATE CONTRACT TIME NUMBER 1 AND LIQUIDATED DAMAGES

The Contractor will be required to pick up the litter/debris and remove the trash bags from the specific location(s), as notified by the Department. The Contractor is required to mobilize and start litter/debris removal within **seven (7) days of the notification of said location(s)**. The Contractor will be required to prosecute the work in a continuous and uninterrupted manner from the time they begin the work until completion of litter removal at the location. In the event that the Contractor fails to mobilize and start the litter and trash bag removal within seven (7) days, liquidated damages will be assessed. In the event that the Contractor does not prosecute the work in a continuous and uninterrupted manner from the time they begin the work until completion of litter/debris removal at the location(s), liquidated damages will be assessed.

All litter collection and trash bag removal shall be complete within **fourteen (14) days of notification of location(s) unless a shorter time frame is determined by the Engineer**. In the event the Contractor fails to remove the litter and trash bags within the allotted time frame, liquidated damages will be assessed.

Liquidated damages for this contract are Six Hundred Dollars (\$600.00) for each twenty-four (24) hour period that the Contractor fails to mobilize and begin litter/debris removal after seven (7) days of the initial notification, as required by this contract.

Liquidated damages for this contract are Six Hundred Dollars (\$600.00) for each twenty-four (24) hour period that the Contractor fails to prosecute the work in a continuous and uninterrupted manner once litter/debris removal has begun.

Liquidated damages for this contract are Six Hundred Dollars (\$600.00) for each twenty-four (24) hour period that the Contractor fails to complete the litter collection and trash bag removal within the allotted time frame from the time of notification, as

required by this contract.

The Contractor shall remove all bags and piles of refuse by the end of the work day unless approved by the Engineer or his/her representative. The liquidated damages for not complying with the removal of litter/debris will be **Six Hundred Dollars (\$600.00)** per calendar day.

The Contractor must complete one (1) litter/debris pickup area prior to moving to the next (not to exceed over five (5) miles). The liquidated damages are **Six Hundred Dollars (\$600.00)** per incident for moving to the next area prior to completion of the existing area.

Any damages assessed under ICT #1 will be withheld from monies due the Contractor on the next partial payment for work accomplished and accepted.

INTERMEDIATE CONTRACT TIME NUMBER 2 AND LIQUIDATED DAMAGES:

(2-20-07)

108

SP1 G14 A

The Contractor shall complete the required work of installing, maintaining, and removing the traffic control devices for lane closures and restoring traffic to the existing traffic pattern. The Contractor shall not close or narrow a lane of traffic on **ANY ROAD** during the following time restrictions:

DAY AND TIME RESTRICTIONS

No Night Work.

In addition, the Contractor shall not close or narrow a lane of traffic on **ANY ROAD**, detain and/or alter the traffic flow on or during holidays, holiday weekends, special events, or any other time when traffic is unusually heavy, including the following schedules:

HOLIDAY AND HOLIDAY WEEKEND LANE CLOSURE RESTRICTIONS

1. For **unexpected occurrence** that creates unusually high traffic volumes, as directed by the Engineer.
2. For **New Year's Day**, between the hours of **4:00 PM** December 31st and **8:30 AM** January 2nd. If New Year's Day is on a Friday, Saturday, Sunday or Monday, then until **8:30 AM** the following Tuesday.
3. For **Easter**, between the hours of **4:00 PM** Thursday and **8:30 AM** Monday.
4. For **Memorial Day**, between the hours of **4:00 PM** Friday and **8:30 AM** Tuesday.
5. For **Independence Day**, between the hours of **4:00 PM** the day before Independence Day and **8:30 AM** the day after Independence Day.

If **Independence Day** is on a Friday, Saturday, Sunday or Monday, then between the hours of **4:00 PM** the Thursday before Independence Day and **8:30 AM** the Tuesday after Independence Day.

6. For **Labor Day**, between the hours of **4:00 PM** Friday and **8:30 AM** Tuesday.
7. For **Thanksgiving Day**, between the hours of **4:00 PM** Tuesday and **8:30 AM** Monday.
8. For **Christmas**, between the hours of **4:00 PM** the Friday before the week of Christmas Day and **8:30 AM** the following Tuesday after the week of Christmas Day.

Holidays and holiday weekends shall include New Year's, Easter, Memorial Day, Independence Day, Labor Day, Thanksgiving, and Christmas. The Contractor shall schedule his work so that lane closures will not be required during these periods, unless otherwise directed by the Engineer.

The time of availability for this intermediate contract work shall be the time the Contractor begins to install all traffic control devices for lane closures according to the time restrictions listed herein.

The completion time for this intermediate contract work shall be the time the Contractor is required to complete the removal of all traffic control devices for lane closures according to the time restrictions stated above and place traffic in the existing traffic pattern.

The liquidated damages are **Six Hundred Dollars (\$ 600.00)** per hour.

INTERMEDIATE CONTRACT TIME NUMBER 3 AND LIQUIDATED DAMAGES:

The Contractor shall maintain traffic during construction and provide, install, and maintain all traffic control devices in accordance with these project guidelines, the Project Traffic Control Plans, the Project Special Provisions, North Carolina Department of Transportation Standard Specifications for Roads and Structures 2024, and the current edition of the Manual of Uniform Traffic Control Devices (MUTCD).

The Contractor shall utilize complete and proper traffic controls and traffic control devices during all operations. All traffic control and traffic control devices required for any operation shall be functional and in place prior to the commencement of that operation. Signs for temporary operations shall be removed during periods of inactivity. The Contractor is required to leave the project in a manner that will be safe to the traveling public and which will not impede motorists.

Traffic movements through lane closures on roads with two way traffic shall be controlled by flaggers stationed at each end of the work zone. In situations where sight distance is limited, the Contractor shall provide additional means of controlling traffic, including, but not limited to, two-way radios, pilot vehicles, or additional flaggers.

Flaggers shall be competent personnel, adequately trained in flagging procedures, and furnished with proper safety devices and equipment, including, but not limited to, safety vests and stop/slow paddles.

All personnel when working in traffic areas or areas in close proximity to traffic shall wear

an approved safety vest, or shirt or jacket which meets the color requirements of the Manual of Uniform Traffic Control Devices (MUTCD).

The Contractor shall comply with all applicable Federal, State, and local laws, ordinances, and regulations governing safety, health, and sanitation, and shall provide all safeguards, safety devices, and protective equipment, and shall take any other needed actions, on his own responsibility that are reasonably necessary to protect the life and health of employees on the job and the safety of the public, and to protect property in connection with the performance of the work covered by the contract.

Failure to comply with any of the requirements for safety and traffic control of this contract shall result in suspension of work as provided in Subarticle 108-7(2) of the Standard Specifications.

The Contractor's vehicles and equipment shall not be parked within the State Highway System right of way overnight or at other times when work has been suspended unless approved by the Engineer, and in no case within 30 feet of the edge of pavement. The Engineer may designate specific locations for parking equipment.

Traffic Control will be incidental to the work, and will be included in the unit bid price for the other items included in the contract.

The liquidated damages for failing to place signs before commencement of operations is **Six Hundred Dollars (\$600.00)** per incident. All signs shall be clean, legible, and in good condition as determined by the Engineer.

In addition, the Contractor shall incur immediate Liquidated Damages in the amount of **Six Hundred Dollars (\$600.00)** each occurrence for failure to provide operational lighting and signing on all equipment as specified.

INTERMEDIATE CONTRACT TIME NUMBER 4 AND LIQUIDATED DAMAGES:

SAFETY VESTS

All Contractor's personnel, all subcontractors and their personnel, and any material suppliers and their personnel, must wear a reflective safety vest or outer garment meeting ANSI/ISEA 107-2004 Class 2 standards at all times while on the project.

Failure to comply with this provision may result in a fine of **One Hundred Dollars (\$100.00)** for each occurrence.

SUPERVISION BY CONTRACTOR

At all times during the life of the project the Contractor shall provide one permanent employee who shall have the authority and capability for overall responsibility of the project and who shall be personally available at the work site within 24 hours' notice. Such employee shall be fully authorized to conduct all business with the subcontractors, to

negotiate and execute all supplemental agreements, and to execute the orders or directions of the Engineer.

At all times that work is actually being performed, the Contractor shall have present on the project one competent individual who is authorized to act in a supervisory capacity over all work on the project, including work subcontracted. The individual who has been so authorized shall be experienced in the type of work being performed and shall be fully capable of managing, directing, and coordinating the work; of reading and thoroughly understanding the contract; and receiving and carrying out directions from the Engineer or his authorized representatives. He shall be an employee of the Contractor unless otherwise approved by the Engineer.

The Contractor may, at his option, designate one employee to meet the requirements of both positions. However, whenever the designated employee is absent from the work site, an authorized individual qualified to act in a supervisory capacity on the project shall be present.

NO MAJOR CONTRACT ITEMS:

(2-19-02)(Rev. 8-21-07)

104

SP1 G31

None of the items included in this contract will be major items.

NO SPECIALTY ITEMS:

(7-1-95)(Rev. 1-16-24)

108-6

SP1 G34

None of the items included in this contract will be specialty items (see Article 108-6 of the *Standard Specifications*).

FUEL PRICE ADJUSTMENT PAPER BID:

(11-15-05)(Rev. 1-16-24)

109-8

SP1 G44

Revise the *Standard Specifications* as follows:

Page 1-82, Article 109-8, FUEL PRICE ADJUSTMENTS, add the following:

The base index price for DIESEL #2 FUEL is \$ **2.6456** per gallon. Where any of the following are included as pay items in the contract, they will be eligible for fuel price adjustment.

The pay items and the fuel factor used in calculating adjustments to be made will be as follows:

Description	Units	Fuel Usage Factor Diesel
Unclassified Excavation	Gal/CY	0.29
Borrow Excavation	Gal/CY	0.29
Class IV Subgrade Stabilization	Gal/Ton	0.55
Aggregate Base Course	Gal/Ton	0.55
Sub-Ballast	Gal/Ton	0.55
Erosion Control Stone	Gal/Ton	0.55
Rip Rap, Class _____	Gal/Ton	0.55
Asphalt Concrete Base Course, Type _____	Gal/Ton	0.90 or 2.90
Asphalt Concrete Intermediate Course, Type _____	Gal/Ton	0.90 or 2.90
Asphalt Concrete Surface Course, Type _____	Gal/Ton	0.90 or 2.90
Open-Graded Asphalt Friction Course	Gal/Ton	0.90 or 2.90
Permeable Asphalt Drainage Course, Type _____	Gal/Ton	0.90 or 2.90
Sand Asphalt Surface Course, Type _____	Gal/Ton	0.90 or 2.90
Ultra-thin Bonded Wearing Course	Gal/Ton	0.90 or 2.90
Aggregate for Cement Treated Base Course	Gal/Ton	0.55
Portland Cement for Cement Treated Base Course	Gal/Ton	0.55
> 11" Portland Cement Concrete Pavement	Gal/SY	0.327
Concrete Shoulders Adjacent to > 11" Pavement	Gal/SY	0.327
9" to 11" Portland Cement Concrete Pavement	Gal/SY	0.272
Concrete Shoulders Adjacent to 9" to 11" Pavement	Gal/SY	0.272
< 9" Portland Cement Concrete Pavement	Gal/SY	0.245
Concrete Shoulders Adjacent to < 9" Pavement	Gal/SY	0.245

For the asphalt items noted in the chart as eligible for fuel adjustments, the bidder may include the *Fuel Usage Factor Adjustment Form for Paper Bid* with their bid submission if they elect to use the fuel usage factor. The *Fuel Usage Factor Adjustment Form for Paper Bid* is included toward the end of this paper bid document when asphalt items noted in the chart as eligible for fuel adjustments are part of the project.

Select either 2.90 Gal/Ton fuel factor or 0.90 Gal/Ton fuel factor for each asphalt line item on the *Fuel Usage Factor Adjustment Form for Paper Bid*. The selected fuel factor for each asphalt item will remain in effect for the duration of the contract.

Failure to complete the *Fuel Usage Factor Adjustment Form for Paper Bid* will result in using 2.90 gallons per ton as the Fuel Usage Factor for Diesel for the asphalt items noted above. The contractor will not be permitted to change the Fuel Usage Factor after the bids are submitted.

SCHEDULE OF ESTIMATED COMPLETION PROGRESS:

(7-15-08)(Rev. 1-16-24)

108-2

SP1 G58

The Contractor's attention is directed to the Standard Special Provision entitled *Availability of Funds Termination of Contracts* included elsewhere in this proposal. The Department of Transportation's schedule of estimated completion progress for this project as required by that Standard Special Provision is as follows:

	<u>Fiscal Year</u>	<u>Progress (% of Dollar Value)</u>
2025	(7/01/24 - 6/30/25)	91% of Total Amount Bid
2026	(7/01/25 - 6/30/26)	9% of Total Amount Bid

The Contractor shall also furnish his own progress schedule in accordance with Article 108-2 of the *Standard Specifications*. Any acceleration of the progress as shown by the Contractor's progress schedule over the progress as shown above shall be subject to the approval of the Engineer.

SMALL BUSINESS ENTERPRISE (MULTI-YEAR MAINTENANCE CONTRACTS):

(4-20-21)(Rev. 2-15-22)

SP1 G74

This contract is a multi-year maintenance contract let pursuant to the Small Business Enterprise provisions of N.C. General Statute §136-28.10. No minimum quantity of services is guaranteed to be awarded bidders under this contract. In accordance with N.C. General Statute §136-28.10, an award in a contract may be for an amount less but shall not exceed \$1,000,000 per year. No payments in excess of this amount will be disbursed, in accordance with the Statute.

RESTRICTIONS ON ITS EQUIPMENT AND SERVICES:

(11-17-20)

SP01 G090

All telecommunications, video or other ITS equipment or services installed or utilized on this project must be in conformance with UNIFORM ADMINISTRATIVE REQUIREMENTS, COST PRINCIPLES, AND AUDIT REQUIREMENTS FOR FEDERAL AWARDS 2 CFR, § 200.216 **Prohibition on certain telecommunications and video surveillance services or equipment.**

USE OF UNMANNED AIRCRAFT SYSTEM (UAS):

(8-20-19)

SP1 G092

The Contractor shall adhere to all Federal, State and Local regulations and guidelines for the use of Unmanned Aircraft Systems (UAS). This includes but is not limited to US 14 CFR Part 107 *Small UAS Rule*, NC GS 15A-300.2 *Regulation of launch and recovery sites*, NC GS 63-95 *Training required for the operation of unmanned aircraft systems*, NC GS 63-96 *Permit required for commercial operation of unmanned aircraft system*, and NCDOT UAS Policy. The required operator certifications include possessing a current Federal Aviation Administration (FAA) Remote Pilot Certificate, a NC UAS Operator Permit as well as operating a UAS registered with the FAA.

Prior to beginning operations, the Contractor shall complete the NCDOT UAS – Flight Operation Approval Form and submit it to the Engineer for approval. All UAS operations shall be approved by the Engineer prior to beginning the operations.

All contractors or subcontractors operating UAS shall have UAS specific general liability insurance to cover all operations under this contract.

The use of UAS is at the Contractor's discretion. No measurement or payment will be made for the use of UAS. In the event that the Department directs the Contractor to utilize UAS, payment will be in accordance with Article 104-7 Extra Work.

EQUIPMENT IDLING GUIDELINES:

(1-19-21)

107

SP1 G096

Exercise reduced fuel consumption and reduced equipment emissions during the construction of all work associated with this contract. Employees engaged in the construction of this project should turn off vehicles when stopped for more than thirty (30) minutes and off-highway equipment should idle no longer than fifteen (15) consecutive minutes.

These guidelines for turning off vehicles and equipment when idling do not apply to:

1. Idling when queuing.
2. Idling to verify the vehicle is in safe operating condition.
3. Idling for testing, servicing, repairing or diagnostic purposes.
4. Idling necessary to accomplish work for which the vehicle was designed (such as operating a crane, mixing concrete, etc.).
5. Idling required to bring the machine system to operating temperature.
6. Emergency vehicles, utility company, construction, and maintenance vehicles where the engines must run to perform needed work.
7. Idling to ensure safe operation of the vehicle.
8. Idling when the propulsion engine is providing auxiliary power for other than heating or air conditioning. (such as hydraulic systems for pavers)
9. When specific traffic, safety, or emergency situations arise.
10. If the ambient temperature is less than 32 degrees Fahrenheit. Limited idling to provide for the safety of vehicle occupants (e.g. to run the heater).
11. If the ambient temperature is greater than 90 degrees Fahrenheit. Limited idling to provide for the safety of vehicle occupants of off-highway equipment (e.g. to run the air conditioning) no more than 30 minutes.
12. Diesel powered vehicles may idle for up to 30 minutes to minimize restart problems.

Any vehicle, truck, or equipment in which the primary source of fuel is natural gas or electricity is exempt from the idling limitations set forth in this special provision.

OUTSOURCING OUTSIDE THE USA:

(9-21-04) (Rev. 5-16-06)

SP1 G150

All work on consultant contracts, services contracts, and construction contracts shall be performed in the United States of America. No work shall be outsourced outside of the United States of America.

Outsourcing for the purpose of this provision is defined as the practice of subcontracting labor, work, services, staffing, or personnel to entities located outside of the United States.

The North Carolina Secretary of Transportation shall approve exceptions to this provision in writing.

PROJECT SPECIAL PROVISIONS**ROADWAY****BURNING RESTRICTIONS:**

(7-1-95)

200, 210, 215

SP2 R05

Open burning is not permitted on any portion of the right-of-way limits established for this project. Do not burn the clearing, grubbing or demolition debris designated for disposal and generated from the project at locations within the project limits, off the project limits or at any waste or borrow sites in this county. Dispose of the clearing, grubbing and demolition debris by means other than burning, according to state or local rules and regulations.

UTILITY CONFLICTS

Special care shall be used in working around or near existing utilities, protecting them when necessary to provide uninterrupted service. In the event that any utility service is interrupted, the Contractor shall notify the utility owner immediately and shall cooperate with the owner, or his representative, in the restoration of service in the shortest time possible. Existing fire hydrants shall be kept accessible to fire departments at all times.

The Contractor shall adhere to all applicable regulations and follow accepted safety procedures when working in the vicinity of utilities in order to insure the safety of construction personnel and the public.

DRIVEWAYS AND PRIVATE PROPERTY

The Contractor shall maintain access to driveways for all residents, businesses, and property owners throughout the life of the project. The Contractor shall not perform work for private citizens or agencies in conjunction with this project or within the project limits of this contract.

REPORTING

The Contractor shall report online the amount of bags of litter/debris and recycling on the NCDOT Litter Management Website:

<https://apps.ncdot.gov/LM>

The Contractor is required to report all pickups on the date of the pickup. Payment for litter pickup invoiced will not be paid unless reported.

HAZARDOUS, CONTAMINATED, AND/OR TOXIC MATERIAL

The Contractor's personnel shall not be responsible for removing hazardous materials from the right-of-ways, but shall notify an NCDOT representative as soon as possible.

When the Contractor's operations encounter or expose any abnormal condition which may indicate the presence of a hazardous, contaminated, and/or toxic material, such operations shall be discontinued in the vicinity of the abnormal condition and the Engineer shall be notified immediately.

The Contractor will not be responsible for the clean-up and removal of dead animals. If this situation is encountered, the Contractor shall contact the Engineer as directed.

NOTIFICATION OF WORK

The NCDOT will notify the Contractor of each location on the state highway system where litter collection and removal is required and the time frame in which the work is to be completed. Notification may be made by telephone or email and either method shall be considered sufficient. At the time of notification the Engineer shall inform the Contractor of the system type so that the Contractor can plan their operations and work zone traffic control. The Contractor shall notify the NCDOT by email when litter collection and trash bag removal is completed. All work shall be subject to inspection by the Engineer at any time.

Note: It is the responsibility of the Contractor to check and read emails. Failure by the Contractor to read emails will not void the formal notification date.

SAFETY

Contractor performing Work Zone Traffic Control shall have a minimum of one (1) NCDOT Certified Work Zone Supervisor. At no time during the contract is the Contractor to be without a NCDOT Certified Work Zone Supervisor. The NCDOT Certified Work Zone Supervisor must be on site during any traffic control activities that take place within the travel lane or otherwise alter the flow of traffic.

All stages of the litter/debris removal operation shall be accomplished in accordance with the "Work Zone Traffic Control Guidance for Litter/Debris Removal" in the Appendix. The NCDOT Certified Work Zone Supervisor shall submit traffic control plans for the approval of the Engineer, who may adjust or require additional control measures if warranted.

All Contractors' personnel, all subcontractors and their personnel must wear steel toed work boots that meet ASTM F2412.05 and long pants. The Contractor will be held responsible for all damage or injury to property of any character resulting from any act, omission, negligence, or misconduct in the prosecution of the work. When any direct or indirect damage or injury is done to public or private property by or on account of any act, omission, negligence, or misconduct in the execution of the work, the Contractor shall either restore at his/her own expense such property to a condition similar or equal to that existing before such damage or injury was done, or shall make good such damage or injury in a manner acceptable to the owner of the damaged property and to the Department. In case of failure on the part of the Contractor to restore such property or make good such damage or injury the Department may at the Contractor's expense repair, rebuild, or otherwise restore such property in such manner, as the Engineer may consider necessary.

The Contractor's operations are restricted to daylight hours. Work shall only be performed when weather and visibility conditions allow safe operations.

EQUIPMENT REQUIREMENTS

The Contractor shall furnish equipment of sufficient type, capacity, and quantity to safely and efficiently perform the litter/debris removal work. All vehicles used by the Contractor must be performance worthy by visual and operational inspection. The Contractor shall display and telephone number the company name on each piece of equipment. Side by side utility vehicles with beds capable of carrying litter bags with specified warning lights may be allowed for bag pickup only. Four wheeler vehicles will not be allowed.

All vehicles, including trailers, used in the removal operation should be properly equipped with lighting per Roadway Standard Drawing 1165.01 Sheet 1 of 1. Trailers shall have rear mounted strobe lights, mounted as high as possible to enhance visibility.

The Contractor shall furnish, mount, and maintain a W10-11 or W10-11A "DEBRIS PICK UP FREQUENT STOPS" sign on the rear of each vehicle or trailer such that they can be easily read by motorists approaching from the rear. Details of the sign is included in the "Work Zone Traffic Control Guidance for Litter/Debris Removal" of this proposal. The sign must not obstruct any safety lighting or the operator's view.

The Contractor shall be responsible for the equipment provided in this contract at all times and at all locations during the term of the contract. The Contractor shall have no claim against the Department of Transportation for any expense involving damage or loss to the Contractor's equipment (including vandalism, theft, fire and acts of God, etc.) arising out of, or relating to, work performed under this agreement.

The safety of the public and the convenience of traffic shall be regarded as prime importance. The Contractor shall operate the equipment in a safe manner so as not to create a hazard to the traveling public. Crossing lanes of traffic and erratic driving will be strictly prohibited.

Signs, lights, safety, and other traffic control items are not a pay item, but are considered incidental to other contract items and the Contractor is expected to provide these items.

BID ITEMS

This contract will consist of the following seven (7) pay items:

1. **Litter/Debris Removal and Recycling on Interstate Highways per Shoulder Mile:** This item will account for the litter/debris removal and recycling along interstate highways. The designated area for litter/debris removal will be the entire highway corridor from control fence to control fence or the entire right of way width, including median and interchange areas as directed by the Engineer.
2. **Litter/Debris Removal and Recycling on Primary Divided Highways per Shoulder Mile:** This item will account for the litter/debris removal and recycling along urban and rural primary divided highways. The designated area for litter/debris removal will be the entire highway corridor from control fence to control fence or the entire right of way width, including median and interchange areas as directed by the Engineer.
3. **Litter/Debris Removal and Recycling on Primary Undivided Highways per Shoulder Mile:** This item will account for the litter/debris removal and recycling along urban and rural primary undivided highways. The designated area for litter/debris removal will be the entire right of way width or as directed by the Engineer.
4. **Litter/Debris Removal and Recycling on Secondary Divided Highways per Shoulder Mile:** This item will account for the litter/debris removal and recycling along urban and rural secondary divided highways. The designated area for litter/debris removal will be the entire highway corridor from control fence to control fence or the entire right of way width, including median and interchange areas as directed by the Engineer.
5. **Litter/Debris Removal and Recycling on Secondary Undivided Highways per Shoulder Mile:** This item will account for the litter/debris removal and recycling along urban and rural secondary undivided highways. The designated area for litter/debris removal will be the entire right of way width or as directed by the Engineer.
6. **Litter/Debris Removal and Recycling at Isolated Dump Sites per Each:** This item will account for the litter/debris removal and recycling at isolated dump sites along highways. The designated area for litter/debris removal will be the entire right of way length and/or width, or as directed by the Engineer.
7. **Litter/Debris Removal and Recycling of Isolated Bulk Items per Each.** This item will account for the litter/debris removal and recycling of isolated bulk item(s) along highways. The designated item(s) for litter/debris removal will be as directed by the Engineer.

QUALITY, INSPECTION AND BASIS OF ACCEPTANCE

It is intended that the work will be completed in a neat, continuous, and uninterrupted manner as determined by the Engineer. Completed work shall be clean and free of all accumulated litter/debris immediately after litter/debris removal and recycling. All work shall be subject to inspection by the Engineer at any time. The Engineer or a designated representative will make periodic next day inspections of the completed work. **It will be the responsibility of the Contractor to keep the Engineer informed of his/her proposed work plan by submitting weekly reports of work accomplished and of planned work for the upcoming week. The Contractor shall notify the NCDOT by email when litter collection and trash bag removal is completed.**

The Department of Transportation will verify completion of the Contractor's work on a monthly basis before payment of invoice.

METHOD OF MEASUREMENT

The quantity of Litter/Debris Removal and Recycling will be measured to the nearest (0.1) tenth of a mile for each Shoulder Mile of Litter/Debris Removal and Recycling work accomplished and accepted.

Highway mileage will be determined from NCDOT county maintenance maps. In the case of dispute or obvious error, the mileage shall be measured by a representative of the North Carolina Department of Transportation and the Contractor. Normally one (1) map mile of undivided roadway shall equal two (2) shoulder miles and one (1) map mile of divided roadway shall equal four (4) shoulder miles.

BASIS OF PAYMENT

The quantity of Litter/Debris Removal and Recycling on Interstate Highways, measured as provided above, will be paid for at the **Shoulder Mile** price for "Litter/Debris Removal and Recycling on Interstate Highways".

The quantity of Litter/Debris Removal and Recycling on Primary Divided Highways, measured as provided above, will be paid for at the **Shoulder Mile** price for "Litter/Debris Removal and Recycling on Primary Divided Highways".

The quantity of Litter/Debris Removal and Recycling on Primary Undivided Highways, measured as provided above, will be paid for at the **Shoulder Mile** price for "Litter/Debris Removal and Recycling on Primary Undivided Highways".

The quantity of Litter/Debris Removal and Recycling on Secondary Divided Highways, measured as provided above, will be paid for at the **Shoulder Mile** price for "Litter/Debris Removal and Recycling on Secondary Divided Highways".

The quantity of Litter/Debris Removal and Recycling on Secondary Undivided Highways, measured as provided above, will be paid for at the **Shoulder Mile** price for "Litter/Debris Removal and Recycling on Secondary Undivided Highways".

The quantity of Litter/Debris Removal and Recycling at Isolated Dump Sites will be paid for at the **Each** price for "Isolated Dump Sites".

The quantity of Litter/Debris Removal and Recycling of Isolated Bulk Items will be paid for at the **Each** price for "Isolated Bulk Items".

Bid prices and payments will be full compensation for all work, including but not limited to supervision, labor, transportation, fuels, lubricants, repair parts, equipment, machinery, tools, and dumping fees, necessary for the prosecution and completion of the work. Payments will be made to the Contractor for work accomplished and accepted.

Payment for these items will be made for as follows:

Litter/Debris Removal and Recycling on Interstate Highways	SHM
Litter/Debris Removal and Recycling on Primary Divided Highways.....	SHM
Litter/Debris Removal and Recycling on Primary Undivided Highways.....	SHM
Litter/Debris Removal and Recycling on Secondary Divided Highways	SHM
Litter/Debris Removal and Recycling on Secondary Undivided Highways ...	SHM
Isolated Dump Sites (100 SQF).....	EA
Isolated Bulk Items.....	EA

APPENDIX

WORK ZONE TRAFFIC CONTROL GUIDANCE FOR LITTER/DEBRIS REMOVAL

The Contractor performing Work Zone Traffic Control shall have a minimum of one (1) NCDOT Certified Work Zone Supervisor.

GENERAL

- Workers that are involved in litter/debris removal operations shall comply with the following:
 - Wear NCDOT approved safety vests for day time operations
- Litter/debris removal operations shall be confined within a maximum 5 mile stretch of roadway in a work period
- Conduct litter/debris removal operations behind lane closures at any location where workers and/or equipment are encroaching into the travel lanes. Lane closures shall be installed according to Roadway Standard Drawings 1101.02. Encroaching into travel lanes includes exiting and entering vehicles that are parked on shoulders.
- Use the following drawings to retrieve bagged litter/debris and any other materials after being collected by the workers.
- For operations where workers and equipment are confined to the shoulders, comply with the followings:

On Multilane Divided Facilities

- A Truck Mounted Attenuator (TMA) shall be used to protect each group of workers removing litter/debris if the shoulder is wide enough to fit a TMA.
- If a TMA is not used, a shoulder closure shall be installed
- A shoulder closure shall be installed in locations where the shoulder is too narrow to accommodate a TMA without encroaching into the traffic lane
- A shoulder closure or a TMA shall be used on the median side of the opposite direction if the following condition exists:
 - Where workers and/or equipment are within 15' from the adjacent travel lane in the opposite direction and are not protected from traffic in the opposite direction by any type of positive median protection such as concrete barrier, guardrail, or guiderail.

- Shoulder closures shall be installed according to Roadway Standard Drawing 1101.04

Two-Lane, Two-Way Facilities over 4000 ADT

- A shoulder closure shall be installed if workers are to be present more than one hour at any location.
- If workers are to be present less than one hour, use portable advance warning signs (one in each direction) reading “LITTER PICKUP AHEAD”.
- Shoulder closures shall be installed according to Roadway Standard Drawing 1101.04

Two-Lane, Two-Way Facilities 4000 ADT or lower

- Use portable advance warning signs (one in each direction) reading “LITTER PICKUP AHEAD”. The sign should be located 500 feet ahead of the area where workers and or equipment will be present during the operation.

PLEASE NOTE THE FOLLOWING EXCEPTIONS:

The moving caravan operation will NOT be required to be used while retrieving bagged litter/debris in areas where the Contractor's equipment is able to traverse the shoulder without encroaching into the travel lanes.

The truck mounted attenuator (TMA) will NOT be required to be used while retrieving bagged litter/debris in areas where the Contractor's equipment is able to traverse the shoulder without encroaching into the travel lanes.

If the vehicle the Contractor is using is wider than the width of the shoulder a moving caravan operation WILL be required if the Contractor elects to allow the vehicle to encroach into the travel.

The Contractor may elect to park the vehicle outside of these narrow areas and remove bags by hand in lieu of the moving caravan operation.

The truck mounted attenuator (TMA) will NOT be required to protect workers picking up litter/debris if the Contractor's operations are carried out in such a way that the workers are positioned individually along a roadway and not travelling in a concentrated group.

If a concentrated group of workers are gathered together in a formation to conduct clean up then they shall be protected by a TMA.

The shoulder closure will NOT be required unless equipment remains stationary for more than 5 minutes and/or a concentrated group of workers are within 15 feet of an open travel lane and the area is not protected by barrier or guardrail.

The lane closure will NOT be required unless equipment remains stationary for more than five minutes and/or a concentrated group of workers are within 10 feet of an open travel lane and the area is not protected by barrier or guardrail."

A concentrated group of workers is defined as three (3) or more workers within a 500' section and within fifteen (15) feet from a travel lane, measured along the edge of the roadway, of other workers.

WORK ZONE SIGNING:

All portable signs and stands must meet or exceed the requirements of the National Cooperative Highway Research Program Report 350 for Work Zone Category II Devices, and be listed on North Carolina's approved products list or accepted as traffic qualified by the Traffic Control Section. Use portable work zone signs and stands specifically designed for one another.

Refer to the following:

- SSRS 1089 for material specification
- SSRS 1110 for construction specification
- RSD 1110 for clearance specification

The W10-10A shall be used for high volume primary and secondary routes. Its dimensions are 48" X 48". It shall be mounted at a minimum height of five (5) feet above the elevation of the outermost edge of travel. The sign shall read "LITTER PICKUP AHEAD", and should be relocated accordingly during the prosecution of work. Additional signs may be required by the Engineer at interchanges.

Sign Detail for Litter/Debris Removal Vehicle

DETAIL OF SIGN TO BE MOUNTED
ON BACK OF ALL VEHICLES USED FOR
LITTER/DEBRIS REMOVAL

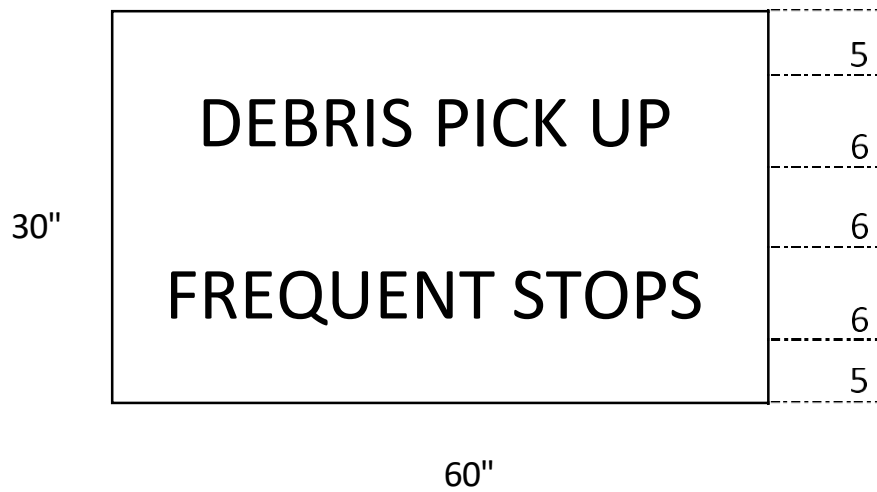

Lettering -
Black

Background - Fluorescent Orange (Retroreflective)

Service Vehicles

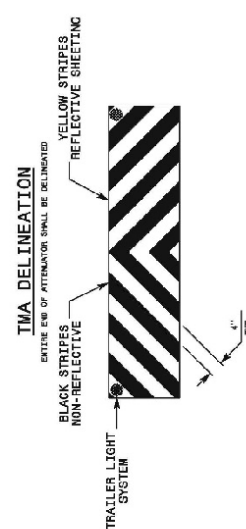
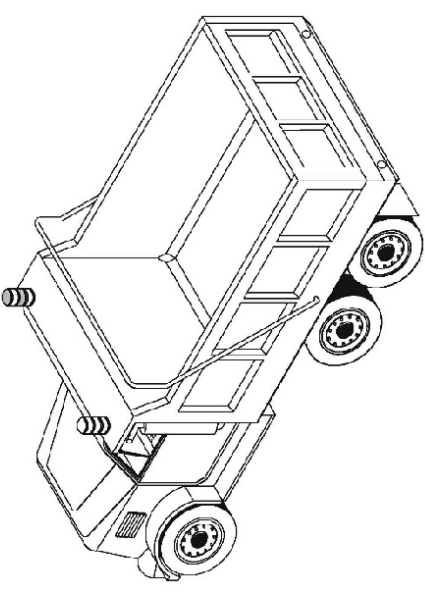
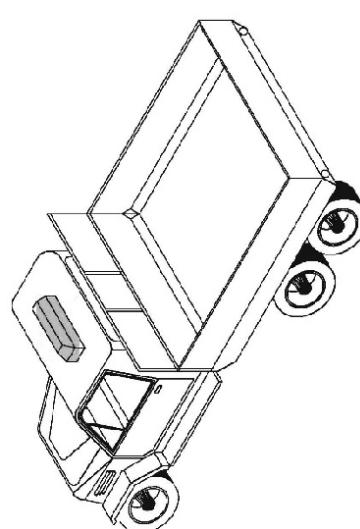
<p style="text-align: center;">STATE OF NORTH CAROLINA DEPT. OF TRANSPORTATION DIVISION OF HIGHWAYS RALEIGH, N.C.</p> <p style="text-align: right;">1-12</p>	<p style="text-align: center;">ENGLISH STANDARD DRAWING FOR WORK VEHICLE LIGHTING SYSTEMS AND TMA DELINEATION</p> <div style="display: flex; justify-content: space-around; align-items: center;"> <div style="width: 45%;"> <p style="text-align: center;">TMA DELINEATION</p>  <p style="text-align: center;">BLACK STRIPES NON-REFLECTIVE</p> <p style="text-align: center;">YELLOW STRIPES REFLECTIVE SHEETING</p> <p style="text-align: center;">TRAILER LIGHT SYSTEM</p> <p style="text-align: center;">ENTIRE END OF ATTENUATOR SHALL BE DELINEATED</p> <p style="text-align: right;">1/4" P.T.</p> </div> <div style="width: 45%;"> <p style="text-align: center;">DUMP BODY</p>  </div> <div style="width: 45%;"> <p style="text-align: center;">NON-DUMP BODY</p>  </div> </div>	<p style="text-align: center;">ENGLISH STANDARD DRAWING FOR WORK VEHICLE LIGHTING SYSTEMS AND TMA DELINEATION</p> <p style="text-align: right;">1165.01</p>
<p style="text-align: center;">STATE OF NORTH CAROLINA DEPT. OF TRANSPORTATION DIVISION OF HIGHWAYS RALEIGH, N.C.</p> <p style="text-align: right;">1-12</p>	<p style="text-align: center;">ENGLISH STANDARD DRAWING FOR WORK VEHICLE LIGHTING SYSTEMS AND TMA DELINEATION</p> <p>GENERAL NOTES FOR TMA REQUIREMENTS</p> <ol style="list-style-type: none"> 1. WHEN TMA'S USED FOR SHADOW VEHICLES, CONTACT THE TMA MANUFACTURER FOR SPECIFIC TRUCK REQUIREMENTS. 2. TMA MUST MEET OR EXCEED THE REQUIREMENTS OF NCHRP 350 TEST LEVEL II FOR WORK ZONES WITH APPROXIMATELY 45 MPH TRUCK SPEEDS. TMA'S MUST BE TESTED AT APPROXIMATELY 45 MPH. THE TESTED SPEED LIMIT OF 60 MPH OR GREATER. TMA MAY EITHER BE TRUCK MOUNTED OR TRAILER MOUNTED. 3. SEE THE DEPARTMENT'S APPROVED PRODUCT LIST AT http://apps.dot.state.nc.us/verdot/approvedproducts. 	<p style="text-align: center;">ENGLISH STANDARD DRAWING FOR WORK VEHICLE LIGHTING SYSTEMS AND TMA DELINEATION</p> <p style="text-align: right;">1165.01</p>
<p>LIGHT SYSTEM OPTIONS</p> <ol style="list-style-type: none"> 1. TRUCKS WITHOUT TRAILER BODIES, MOUNTAGE OR FLARE. <ol style="list-style-type: none"> A. LIGHT BAR (18" WIDE), EITHER LED OR ROTATING FLARE B. LIGHT BAR (18" WIDE), EITHER LED OR ROTATING FLARE C. LIGHT BAR (18" WIDE), EITHER LED OR ROTATING FLARE D. LIGHT BAR (18" WIDE), EITHER LED OR ROTATING FLARE E. LIGHT BAR (18" WIDE), EITHER LED OR ROTATING FLARE F. LIGHT BAR (18" WIDE), EITHER LED OR ROTATING FLARE G. LIGHT BAR (18" WIDE), EITHER LED OR ROTATING FLARE H. LIGHT BAR (18" WIDE), EITHER LED OR ROTATING FLARE I. LIGHT BAR (18" WIDE), EITHER LED OR ROTATING FLARE J. LIGHT BAR (18" WIDE), EITHER LED OR ROTATING FLARE K. LIGHT BAR (18" WIDE), EITHER LED OR ROTATING FLARE L. LIGHT BAR (18" WIDE), EITHER LED OR ROTATING FLARE M. LIGHT BAR (18" WIDE), EITHER LED OR ROTATING FLARE N. LIGHT BAR (18" WIDE), EITHER LED OR ROTATING FLARE O. LIGHT BAR (18" WIDE), EITHER LED OR ROTATING FLARE P. LIGHT BAR (18" WIDE), EITHER LED OR ROTATING FLARE Q. LIGHT BAR (18" WIDE), EITHER LED OR ROTATING FLARE R. LIGHT BAR (18" WIDE), EITHER LED OR ROTATING FLARE S. LIGHT BAR (18" WIDE), EITHER LED OR ROTATING FLARE T. LIGHT BAR (18" WIDE), EITHER LED OR ROTATING FLARE U. LIGHT BAR (18" WIDE), EITHER LED OR ROTATING FLARE V. LIGHT BAR (18" WIDE), EITHER LED OR ROTATING FLARE W. LIGHT BAR (18" WIDE), EITHER LED OR ROTATING FLARE X. LIGHT BAR (18" WIDE), EITHER LED OR ROTATING FLARE Y. LIGHT BAR (18" WIDE), EITHER LED OR ROTATING FLARE Z. LIGHT BAR (18" WIDE), EITHER LED OR ROTATING FLARE 2. TRUCKS WITH TRAILER BODIES, MOUNTAGE OR FLARE. <ol style="list-style-type: none"> A. LIGHT BAR (18" WIDE), EITHER LED OR ROTATING FLARE B. LIGHT BAR (18" WIDE), EITHER LED OR ROTATING FLARE C. LIGHT BAR (18" WIDE), EITHER LED OR ROTATING FLARE D. LIGHT BAR (18" WIDE), EITHER LED OR ROTATING FLARE E. LIGHT BAR (18" WIDE), EITHER LED OR ROTATING FLARE F. LIGHT BAR (18" WIDE), EITHER LED OR ROTATING FLARE G. LIGHT BAR (18" WIDE), EITHER LED OR ROTATING FLARE H. LIGHT BAR (18" WIDE), EITHER LED OR ROTATING FLARE I. LIGHT BAR (18" WIDE), EITHER LED OR ROTATING FLARE J. LIGHT BAR (18" WIDE), EITHER LED OR ROTATING FLARE K. LIGHT BAR (18" WIDE), EITHER LED OR ROTATING FLARE L. LIGHT BAR (18" WIDE), EITHER LED OR ROTATING FLARE M. LIGHT BAR (18" WIDE), EITHER LED OR ROTATING FLARE N. LIGHT BAR (18" WIDE), EITHER LED OR ROTATING FLARE O. LIGHT BAR (18" WIDE), EITHER LED OR ROTATING FLARE P. LIGHT BAR (18" WIDE), EITHER LED OR ROTATING FLARE Q. LIGHT BAR (18" WIDE), EITHER LED OR ROTATING FLARE R. LIGHT BAR (18" WIDE), EITHER LED OR ROTATING FLARE S. LIGHT BAR (18" WIDE), EITHER LED OR ROTATING FLARE T. LIGHT BAR (18" WIDE), EITHER LED OR ROTATING FLARE U. LIGHT BAR (18" WIDE), EITHER LED OR ROTATING FLARE V. LIGHT BAR (18" WIDE), EITHER LED OR ROTATING FLARE W. LIGHT BAR (18" WIDE), EITHER LED OR ROTATING FLARE X. LIGHT BAR (18" WIDE), EITHER LED OR ROTATING FLARE Y. LIGHT BAR (18" WIDE), EITHER LED OR ROTATING FLARE Z. LIGHT BAR (18" WIDE), EITHER LED OR ROTATING FLARE 3. TRUCKS WITH TRAILER BODIES, MOUNTAGE OR FLARE. <ol style="list-style-type: none"> A. LIGHT BAR (18" WIDE), EITHER LED OR ROTATING FLARE B. LIGHT BAR (18" WIDE), EITHER LED OR ROTATING FLARE C. LIGHT BAR (18" WIDE), EITHER LED OR ROTATING FLARE D. LIGHT BAR (18" WIDE), EITHER LED OR ROTATING FLARE E. LIGHT BAR (18" WIDE), EITHER LED OR ROTATING FLARE F. LIGHT BAR (18" WIDE), EITHER LED OR ROTATING FLARE G. LIGHT BAR (18" WIDE), EITHER LED OR ROTATING FLARE H. LIGHT BAR (18" WIDE), EITHER LED OR ROTATING FLARE I. LIGHT BAR (18" WIDE), EITHER LED OR ROTATING FLARE J. LIGHT BAR (18" WIDE), EITHER LED OR ROTATING FLARE K. LIGHT BAR (18" WIDE), EITHER LED OR ROTATING FLARE L. LIGHT BAR (18" WIDE), EITHER LED OR ROTATING FLARE M. LIGHT BAR (18" WIDE), EITHER LED OR ROTATING FLARE N. LIGHT BAR (18" WIDE), EITHER LED OR ROTATING FLARE O. LIGHT BAR (18" WIDE), EITHER LED OR ROTATING FLARE P. LIGHT BAR (18" WIDE), EITHER LED OR ROTATING FLARE Q. LIGHT BAR (18" WIDE), EITHER LED OR ROTATING FLARE R. LIGHT BAR (18" WIDE), EITHER LED OR ROTATING FLARE S. LIGHT BAR (18" WIDE), EITHER LED OR ROTATING FLARE T. LIGHT BAR (18" WIDE), EITHER LED OR ROTATING FLARE U. LIGHT BAR (18" WIDE), EITHER LED OR ROTATING FLARE V. LIGHT BAR (18" WIDE), EITHER LED OR ROTATING FLARE W. LIGHT BAR (18" WIDE), EITHER LED OR ROTATING FLARE X. LIGHT BAR (18" WIDE), EITHER LED OR ROTATING FLARE Y. LIGHT BAR (18" WIDE), EITHER LED OR ROTATING FLARE Z. LIGHT BAR (18" WIDE), EITHER LED OR ROTATING FLARE 	<p style="text-align: center;">ENGLISH STANDARD DRAWING FOR WORK VEHICLE LIGHTING SYSTEMS AND TMA DELINEATION</p> <p style="text-align: right;">1165.01</p>	

Typical Sections for Litter Pickup Operation

TYPICAL INTERCHANGE CONFIGURATIONS

SHOWING THE LIMITS FOR

LITTER/DEBRIS REMOVAL.

- Litter removal includes all areas visible from the road



Litter Pickup Operation Diagrams

Diagram 1

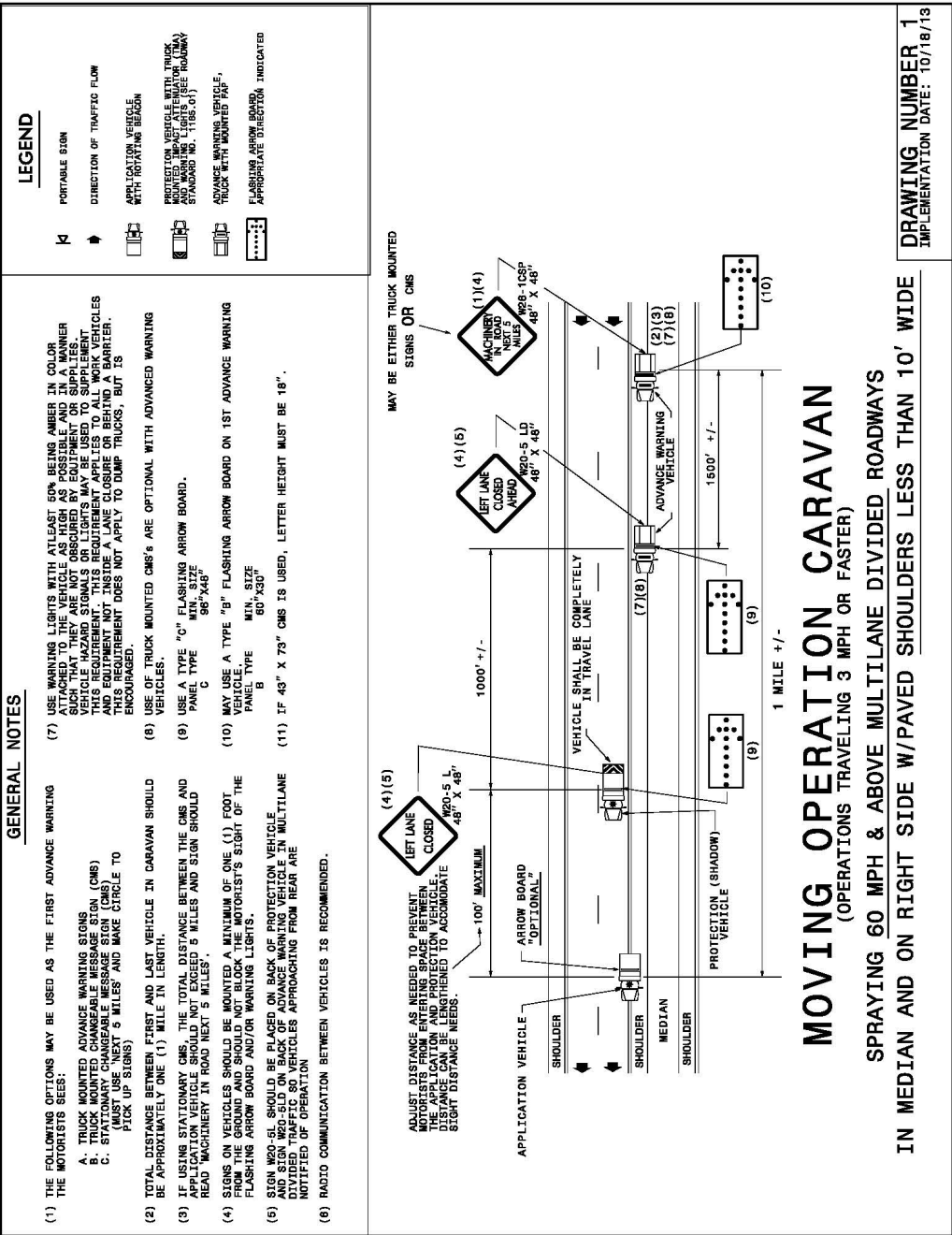

Diagram 2

GENERAL NOTES

(1) THE FOLLOWING OPTIONS MAY BE USED FOR THE FIRST ADVANCE WARNING THE MOTORISTS SEES:
 A. TRUCK MOUNTED ADVANCE WARNING SIGNS
 B. TRUCK MOUNTED CHANGEABLE MESSAGE SIGN (CMS)
 C. STATIONARY CHANGEABLE MESSAGE SIGN (CMS)
 USE NEXT 5 MILES AND MAKE CIRCLE TO PICK UP CMS.

(2) TOTAL DISTANCE BETWEEN FIRST AND LAST VEHICLE IN CARAVAN SHOULD BE APPROXIMATELY ONE (1) MILE IN LENGTH.

(3) IF USING STATIONARY CMS, THE TOTAL DISTANCE BETWEEN THE CMS AND APPLICATION VEHICLE SHOULD NOT EXCEED 5 MILES AND SIGN SHOULD READ "SHOULDER CLOSED".

(4) SIGNS ON VEHICLES SHOULD BE MOUNTED A MINIMUM OF ONE (1) FOOT FROM THE GROUND AND SHOULD NOT BLOCK THE MOTORIST'S SIGHT OF THE FLASHING ARROW BOARD AND/OR WARNING LIGHTS.

(5) SIGN W21-5BSP SHOULD BE PLACED ON BACK OF ADVANCE WARNING VEHICLE IN MULTILANE DIVIDED TRAFFIC SO VEHICLES APPROACHING FROM REAR ARE NOTIFIED OF OPERATION.

(6) RADIO COMMUNICATION BETWEEN VEHICLES IS RECOMMENDED.

(7) USE WARNING LIGHTS WITH ATLEAST 50% BEING AMBER IN COLOR ATTACHED TO THE VEHICLE AS HIGH AS POSSIBLE AND IN A MANNER THAT IS VISIBLE TO TRAFFIC FROM ALL DIRECTIONS. THIS REQUIREMENT APPLIES TO ALL WORK VEHICLES AND EQUIPMENT NOT INSIDE A LANE CLOSURE OR BEHIND A BARRIER. THIS REQUIREMENT DOES NOT APPLY TO DUMP TRUCKS, BUT IS ENCOURAGED.

(8) USE OF CMS'S ARE OPTIONAL WITH ADVANCED WARNING VEHICLES.

(9) USE A TYPE "C" FLASHING ARROW BOARD.
 PANEL TYPE "M" 88" X 48"
 TYPE "C" 88" X 48"

(10) IF 43" X 73" CMS IS USED, LETTER HEIGHT MUST BE 18".

LEGEND

- K PORTABLE SIGN
- ➔ DIRECTION OF TRAFFIC FLOW
- ☐ APPLICATION VEHICLE WITH ROTATING BEACON
- ☐ PROTECTION VEHICLE WITH TRUCK MOUNTED ADVANCE WARNING (TELA STANDARD NO. 1165-01)
- ☐ ADVANCE WARNING VEHICLE WITH FLASHING ARROW BOARD
- ☐ FLASHING ARROW BOARD, TYPE "C"
- ☐ CAUTION MODE

MAY BE EITHER TRUCK MOUNTED SIGNS OR CMS

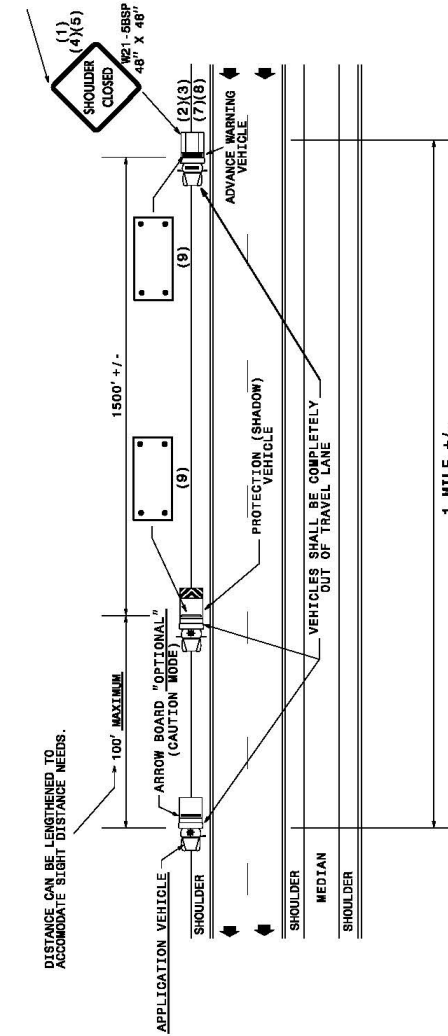

MOVING OPERATION CARAVAN
 (OPERATIONS TRAVELING 3 MPH OR FASTER)

**SPRAYING 60 MPH & ABOVE MULTILANE DIVIDED ROADWAYS
 IN MEDIAN AND ON RIGHT SIDE W/PAVED SHOULDERS 10' OR WIDER**

DRAWING NUMBER 2
 IMPLEMENTATION DATE: 10/18/13

Diagram 3

GENERAL NOTES

- (1) THE FOLLOWING OPTIONS MAY BE USED AS THE FIRST ADVANCE WARNING THE MOTORISTS SEES:
 - A. TRUCK MOUNTED ADVANCE WARNING SIGNS
 - B. MOVING CHANGEABLE MESSAGE SIGN (CMS)
- (2) TOTAL DISTANCE BETWEEN FIRST AND LAST VEHICLE IN CARAVAN SHOULD BE APPROXIMATELY ONE (1) MILE IN LENGTH.
- (3) SIGNS ON VEHICLES SHOULD BE MOUNTED A MINIMUM OF ONE (1) FOOT FROM THE GROUND AND SHOULD NOT BLOCK THE MOTORIST'S SIGHT OF THE FLASHING ARROW BOARD AND/OR WARNING LIGHTS.
- (4) SIGN W20-5L SHOULD BE PLACED ON BACK OF PROTECTION VEHICLE AND BEING USED TO ADVISE TRUCKS APPROACHING FROM REAR ARE NOTIFIED OF OPERATION.
- (5) RADIO COMMUNICATION BETWEEN VEHICLES IS RECOMMENDED.
- (6) USE WARNING LIGHTS WITH ATLEAST 50% BEING AMBER IN COLOR ATTACHED TO THE VEHICLE AS HIGH AS POSSIBLE AND IN A MANNER WHICH IS NOT OBSCURED BY LIGHTS FROM OTHER VEHICLES. THIS REQUIREMENT APPLIES TO ALL WORK VEHICLES AND EQUIPMENT NOT INSIDE A LANE CLOSURE OR BEHIND A BARRIER. THIS REQUIREMENT DOES NOT APPLY TO DUMP TRUCKS, BUT IS ENCOURAGED.
- (7) USE OF CMS'S ARE OPTIONAL WITH ADVANCED WARNING VEHICLES.
- (8) USE A TYPE "C" FLASHING ARROW BOARD.
 - PANEL TYPE C
 - MIN. SIZE 96"x48"
- (9) USE A TYPE "B" FLASHING ARROW BOARD.
 - PANEL TYPE B
 - MIN. SIZE 80"x30"
- (10) IF 43" X 73" CMS IS USED, LETTER HEIGHT MUST BE 18".

LEGEND

- PORTABLE SIGN
- DIRECTION OF TRAFFIC FLOW
- APPLICATION VEHICLE WITH LIGHT BAR
- PROTECTION VEHICLE WITH TRUCK MOUNTED IMPACT ATTENUATOR (TMA) STANDARD NO. 1185-01
- ADVANCE WARNING VEHICLE WITH FLASHING ARROW BOARD
- FLASHING ARROW BOARD TYPE "B" APPROPRIATE DISTRIBUTION INDICATED

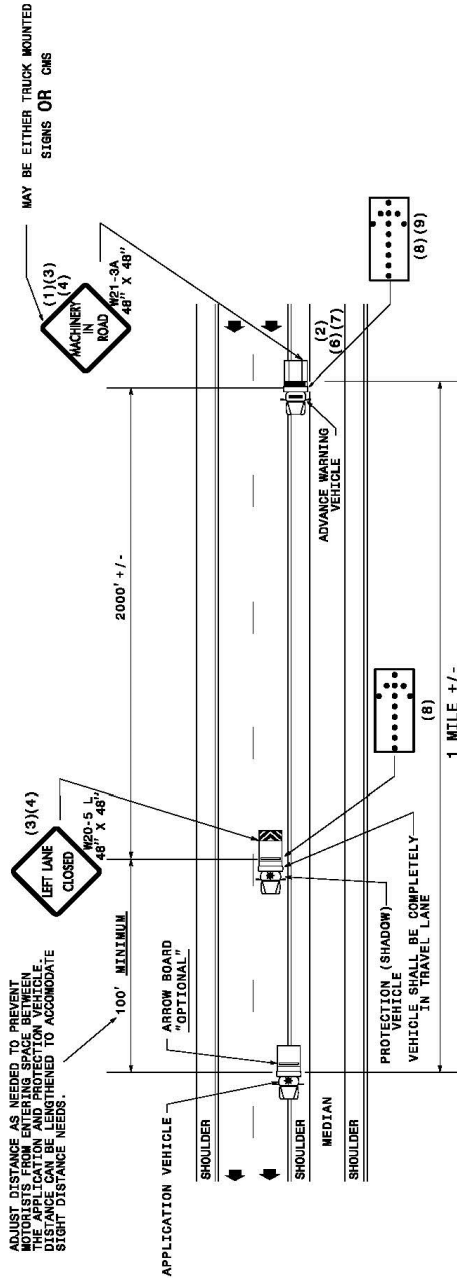

MOVING OPERATION CARAVAN
 (OPERATIONS TRAVELING 3 MPH OR FASTER)

SPRAYING OTHER MULTILANE DIVIDED ROADWAYS

IN MEDIAN AND ON RIGHT SIDE W/PAVED SHOULDERS LESS THAN 10' WIDE

DRAWING NUMBER 3
 IMPLEMENTATION DATE: 10/18/13

Diagram 4

LEGEND

	PORTABLE SIGN
	DIRECTION OF TRAFFIC FLOW
	APPLICATION VEHICLE WITH ROTATING BEACON
	PROTECTION VEHICLE WITH TRUCK AND ROTATING BEACON (SEE ROADWAY STANDARD NO. 1108.01)
	ADVANCE WARNING VEHICLE - 1. S. PICKUP TRUCK WITH MOUNTED SIGN
	FLASHING ARROW BOARD, TYPE "B"
	CAUTION MESSAGE

- GENERAL NOTES**
- (1) THE FOLLOWING OPTIONS MAY BE USED AS THE FIRST ADVANCE WARNING IF THE MOTORISTS SEE:
 - A. TRUCK MOUNTED ADVANCE WARNING SIGNS
 - B. ROTATING CHANGEABLE MESSAGE SIGN (CMS)
 - C. GROUND MOUNTED ADVANCE WARNING SIGN (MUST USE NEXT 5 MILES) AND MAKE CIRCLE TO PICK UP SIGNS
 - D. STATIONARY CHANGEABLE MESSAGE SIGN (CMS) (MUST USE NEXT 5 MILES) AND MAKE CIRCLE TO PICK UP CMS
 - (2) TOTAL DISTANCE BETWEEN FIRST AND LAST VEHICLE IN CARAVAN SHOULD BE APPROXIMATELY ONE (1) MILE IN LENGTH.
 - (3) IF USING GROUND MOUNTED ADVANCE WARNING SIGNS OR STATIONARY CMS, THE TOTAL DISTANCE BETWEEN THE FIRST ADVANCE WARNING SIGN OR CMS AND APPLICATION VEHICLE SHOULD NOT EXCEED 5 MILES AND SIGN W26-1CSP SHOULD READ "MACHINERY IN ROAD NEXT 5 MILES".
 - (4) SIGNS ON VEHICLES SHOULD BE MOUNTED A MINIMUM OF ONE (1) FOOT FROM THE GROUND AND SHOULD NOT BLOCK THE MOTORIST'S SIGHT OF THE FLASHING ARROW BOARD AND/OR LIGHT BAR.
 - (5) SIGN W26-1BSP OR R4-7A SHOULD BE PLACED ON FRONT OF THE APPLICATION VEHICLE AND SIGN W26-1BSP OR W21-3A ON BACK OF THE APPLICATION VEHICLE. FRONT AND REAR ARE NOTIFIED OF OPERATION.
 - (6) IF A LEAD VEHICLE IS ADDED TO OPERATION, IT SHOULD HAVE THE SAME ADVANCE WARNING SIGNS AS THE APPLICATION VEHICLE SHOWN BELOW.
 - (7) RADIO COMMUNICATION BETWEEN VEHICLES IS RECOMMENDED.
 - (8) USE WARNING LIGHTS WITH AT LEAST 50% BEING AMBER IN COLOR ATTACHED TO THE VEHICLE AS HIGH AS POSSIBLE AND IN A MANNER WHICH IS NOT OBSCURED BY LIGHTS FROM OTHER VEHICLES. SUPPLEMENTARY HAZARD SIGNALS OR LIGHTS MAY BE USED TO SUPPLEMENT THIS REQUIREMENT. THIS REQUIREMENT APPLIES TO ALL WORK VEHICLES AND EQUIPMENT NOT INSIDE A LANE CLOSURE OR BEHIND A BARRIER. THIS REQUIREMENT DOES NOT APPLY TO DUMP TRUCKS, BUT IS ENCOURAGED.
 - (9) USE OF CMS'S ARE OPTIONAL WITH ADVANCED WARNING VEHICLES.
 - (10) USE A TYPE "B" FLASHING ARROW BOARD.

A	MIN. SIZE
B	60" X 30"
 - (11) IF 43" X 79" CMS IS USED, LETTER HEIGHT MUST BE 18".

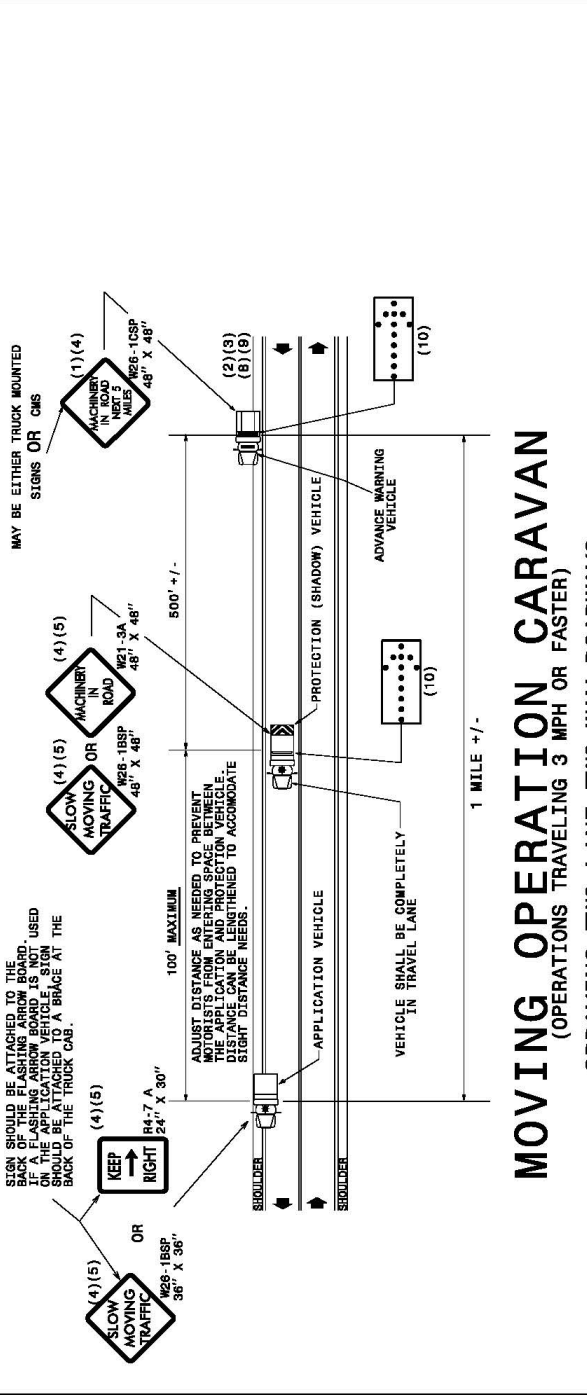

MOVING OPERATION CARAVAN
 (OPERATIONS TRAVELING 3 MPH OR FASTER)
 SPRAYING TWO-LANE TWO-WAY ROADWAYS
 WITH ADT GREATER THAN 5000

DRAWING NUMBER 4
 IMPLEMENTATION DATE: 10/18/13

Diagram 5

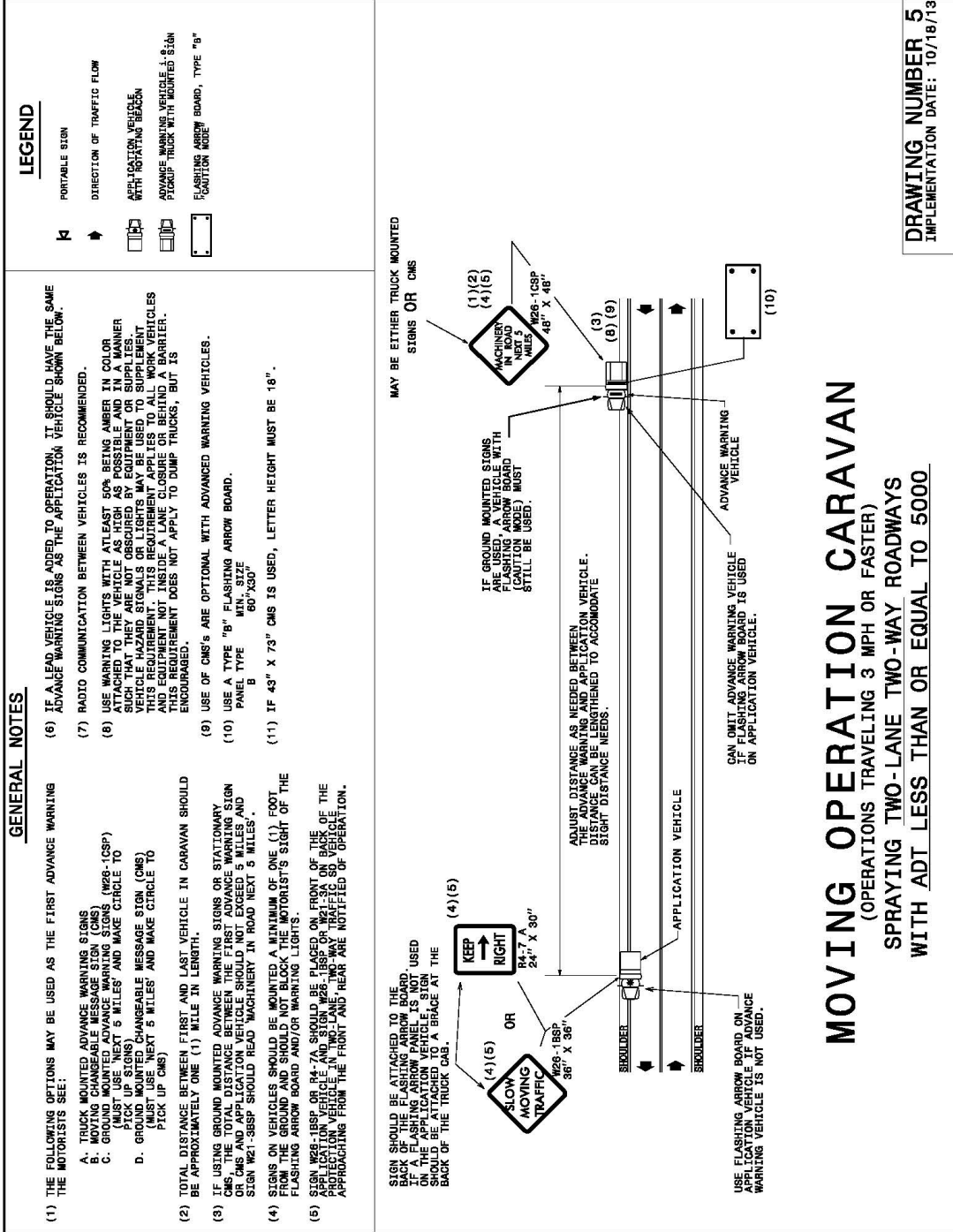

MOVING OPERATION CARAVAN

(OPERATIONS TRAVELING 3 MPH OR FASTER)
 SPRAYING TWO-LANE TWO-WAY ROADWAYS
 WITH ADT LESS THAN OR EQUAL TO 5000

DRAWING NUMBER 5
 IMPLEMENTATION DATE: 10/18/13

Multi-lane Operation Diagrams

Diagram 1

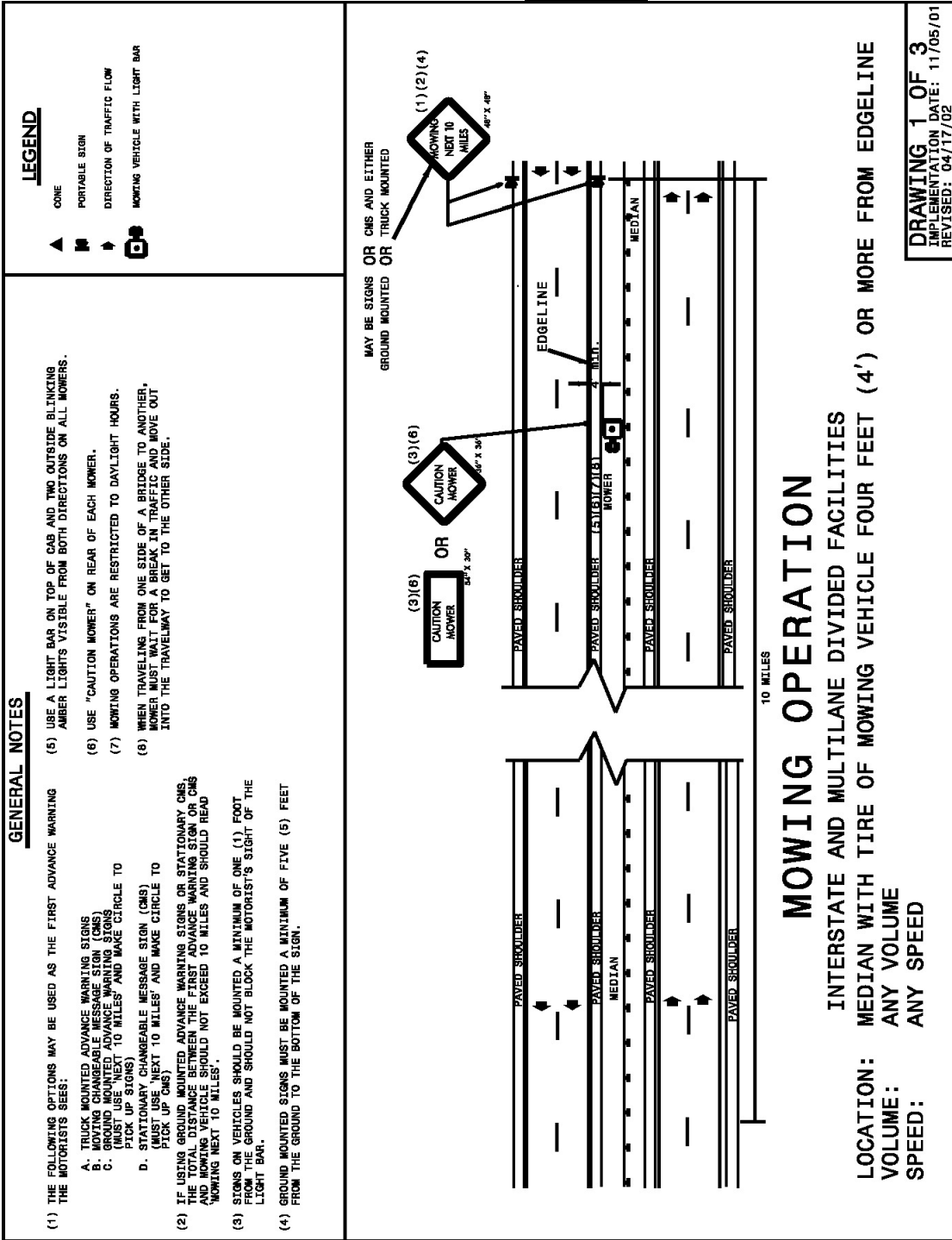

Diagram 2

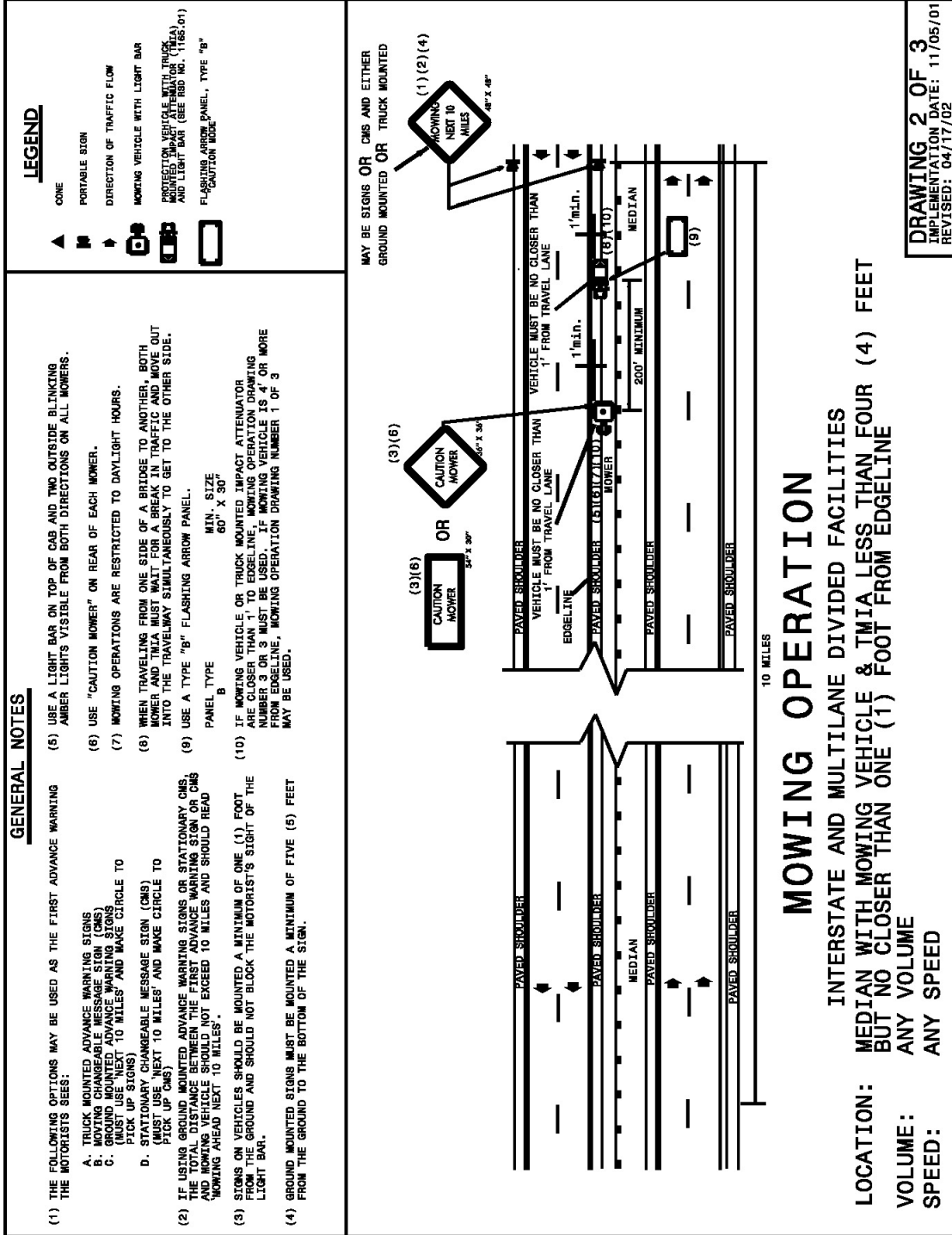
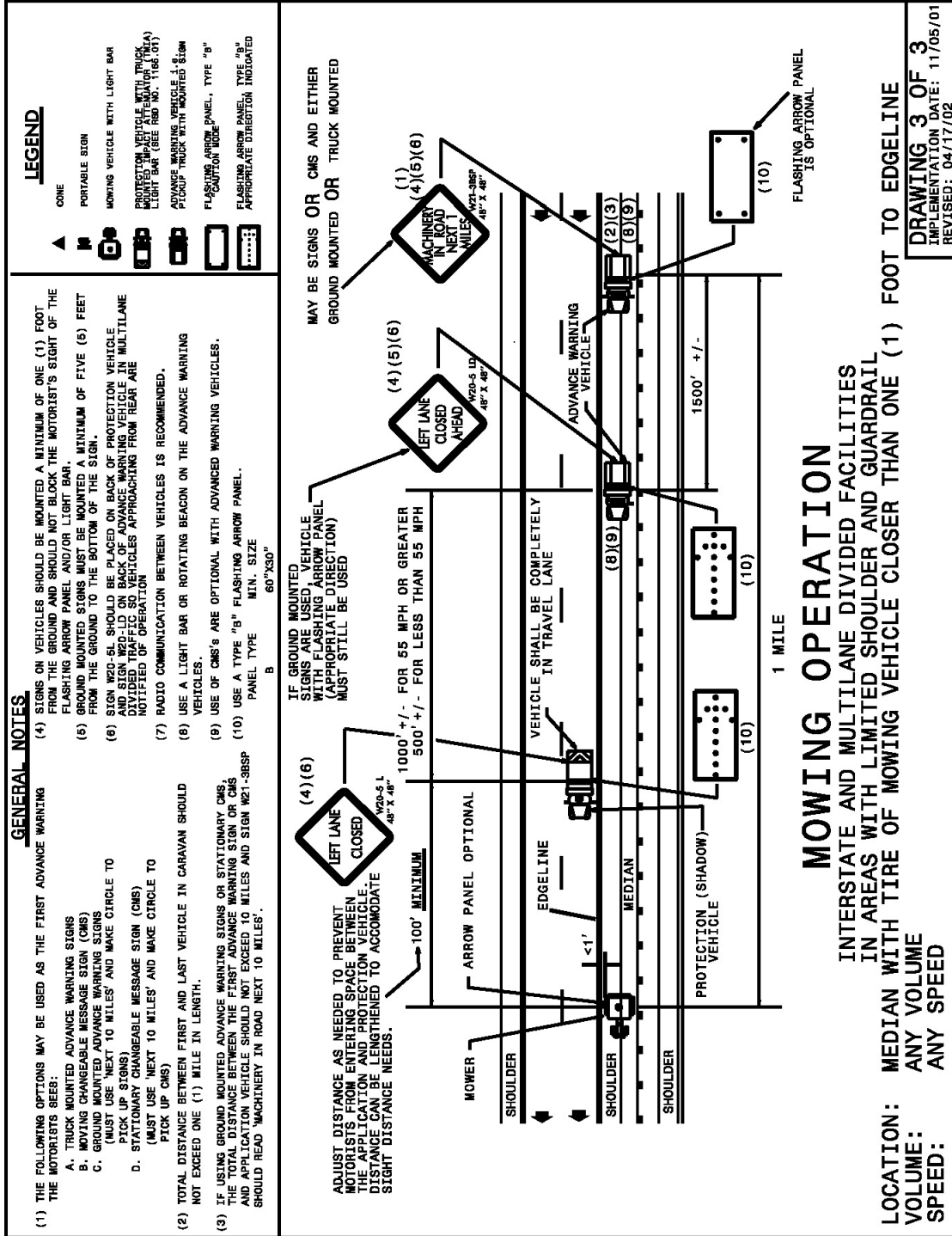

Diagram 3



STANDARD SPECIAL PROVISION
AVAILABILITY OF FUNDS – TERMINATION OF CONTRACTS

(5-20-08)(Rev. 1-16-24)

Z-2

General Statute 143C-6-11. (h) Highway Appropriation is hereby incorporated verbatim in this contract as follows:

(h) Amounts Encumbered. – Transportation project appropriations may be encumbered in the amount of allotments made to the Department of Transportation by the Director for the estimated payments for transportation project contract work to be performed in the appropriation fiscal year. The allotments shall be multiyear allotments and shall be based on estimated revenues and shall be subject to the maximum contract authority contained in *General Statute 143C-6-11(c)*. Payment for transportation project work performed pursuant to contract in any fiscal year other than the current fiscal year is subject to appropriations by the General Assembly. Transportation project contracts shall contain a schedule of estimated completion progress, and any acceleration of this progress shall be subject to the approval of the Department of Transportation provided funds are available. The State reserves the right to terminate or suspend any transportation project contract, and any transportation project contract shall be so terminated or suspended if funds will not be available for payment of the work to be performed during that fiscal year pursuant to the contract. In the event of termination of any contract, the contractor shall be given a written notice of termination at least 60 days before completion of scheduled work for which funds are available. In the event of termination, the contractor shall be paid for the work already performed in accordance with the contract specifications.

Payment will be made on any contract terminated pursuant to the special provision in accordance with Subarticle 108-13(D) of the *Standard Specifications*.

STANDARD SPECIAL PROVISION
ERRATA

(1-16-24)

Z-4

Revise the *2024 Standard Specifications* as follows:

Division 3

Page 3-5, Article 305-2 MATERIALS, after line 16, replace " 1032-3(A)(7)" with "1032-3" and add the item "Galvanized Corrugated Steel Pipe" with Section "1032-3".

Page 3-6, Article 310-2 MATERIALS, after line 9, add the item "Galvanized Corrugated Steel Pipe" with Section "1032-3".

Division 9

Page 9-17, Article 904-4 MEASUREMENT AND PAYMENT, prior to line 1, replace " Sign Erection, Relocate Type (Ground Mounted)" with "Sign Erection, Relocate Type ___ (Ground Mounted)".

Division 10

Page 10-51, Article 1024-4 WATER, prior to line 1, delete the "unpopulated blank row" in Table 1024-2 between "Time of set, deviation from control" and "Chloride Ion Content, Max.".

Page 10-170, Subarticle 1081-1(C) Requirements, line 4, replace "maximum" with "minimum".

Division 11

Page 11-15, Article 1160-4 MEASUREMENT AND PAYMENT, line 24, replace "Where barrier units are moved more than one" with "Where barrier units are moved more than once".

Division 15

Page 15-10, Article 1515-4 MEASUREMENT AND PAYMENT, lines 11, replace " All piping" with "All labor, the manhole, other materials, excavation, backfilling, piping".

Division 16

Page 16-14, Article 1633-5 MEASUREMENT AND PAYMENT, line 20-24 and prior to line 25, delete and replace with the following " *Flocculant* will be measured and paid in accordance with Article 1642-5 applied to the temporary rock silt checks."

Page 16-3, Article 1609-2 MATERIALS, after line 26, replace "Type 4" with "Type 4a".

Page 16-25, Article 1644-2 MATERIALS, after line 22, replace "Type 4" with "Type 4a".

STANDARD SPECIAL PROVISION**PLANT AND PEST QUARANTINES****(Imported Fire Ant, Gypsy Moth, Witchweed, Emerald Ash Borer, Guava Root Knot Nematode, And Other Noxious Weeds)**

(3-18-03) (Rev. 5-21-19)

Z-04a

Within Quarantined Area

This project may be within a county regulated for plant and/or pests. If the project or any part of the Contractor's operations is located within a quarantined area, thoroughly clean all equipment prior to moving out of the quarantined area. Comply with federal/state regulations by obtaining a certificate or limited permit for any regulated article moving from the quarantined area.

Originating in a Quarantined County

Obtain a certificate or limited permit issued by the N.C. Department of Agriculture/United States Department of Agriculture. Have the certificate or limited permit accompany the article when it arrives at the project site.

Contact

Contact the N.C. Department of Agriculture/United States Department of Agriculture at 1-800-206-9333, 919-707-3730, or <https://www.ncagr.gov/plantindustry/Plant/quaran/table2.htm> to determine those specific project sites located in the quarantined area or for any regulated article used on this project originating in a quarantined county.

Regulated Articles Include

1. Soil, sand, gravel, compost, peat, humus, muck, and decomposed manure, separately or with other articles. This includes movement of articles listed above that may be associated with cut/waste, ditch pulling, and shoulder cutting.
2. Plants with roots including grass sod.
3. Plant crowns and roots.
4. Bulbs, corms, rhizomes, and tubers of ornamental plants.
5. Hay, straw, fodder, and plant litter of any kind.
6. Clearing and grubbing debris.
7. Used agricultural cultivating and harvesting equipment.
8. Used earth-moving equipment.
9. Any other products, articles, or means of conveyance, of any character, if determined by an inspector to present a hazard of spreading imported fire ant, gypsy moth, witchweed, emerald ash borer, guava root knot nematode, or other noxious weeds.

STANDARD SPECIAL PROVISION

MINIMUM WAGES

(7-21-09)

Z-5

FEDERAL: The Fair Labor Standards Act provides that with certain exceptions every employer shall pay wages at the rate of not less than SEVEN DOLLARS AND TWENTY FIVE CENTS (\$7.25) per hour.

STATE: The North Carolina Minimum Wage Act provides that every employer shall pay to each of his employees, wages at a rate of not less than SEVEN DOLLARS AND TWENTY FIVE CENTS (\$7.25) per hour.

The minimum wage paid to all skilled labor employed on this contract shall be SEVEN DOLLARS AND TWENTY FIVE CENTS (\$7.25) per hour.

The minimum wage paid to all intermediate labor employed on this contract shall be SEVEN DOLLARS AND TWENTY FIVE CENTS (\$7.25) per hour.

The minimum wage paid to all unskilled labor on this contract shall be SEVEN DOLLARS AND TWENTY FIVE CENTS (\$7.25) per hour.

This determination of the intent of the application of this act to the contract on this project is the responsibility of the Contractor.

The Contractor shall have no claim against the Department of Transportation for any changes in the minimum wage laws, Federal or State. It is the responsibility of the Contractor to keep fully informed of all Federal and State Laws affecting his contract.

STANDARD SPECIAL PROVISION**TITLE VI AND NONDISCRIMINATION:**

(6-28-77)(Rev 1/16/2024)

Z-6

The North Carolina Department of Transportation is committed to carrying out the U.S. Department of Transportation's policy of ensuring nondiscrimination in the award and administration of contracts.

The provisions of this section related to United States Department of Transportation (US DOT) Order 1050.2A, Title 49 Code of Federal Regulations (CFR) part 21, 23 United States Code (U.S.C.) 140 and 23 CFR part 200 (or 49 CFR 303, 49 U.S.C. 5332 or 49 U.S.C. 47123) are applicable to all North Carolina Department of Transportation (NCDOT) contracts and to all related subcontracts, material supply, engineering, architectural and other service contracts, regardless of dollar amount. Any Federal provision that is specifically required not specifically set forth is hereby incorporated by reference.

(1) Title VI Assurances (USDOT Order 1050.2A, Appendix A)

During the performance of this contract, the contractor, for itself, its assignees, and successors in interest (hereinafter referred to as the "contractor") agrees as follows:

(a) Compliance with Regulations

The contractor (hereinafter includes consultants) shall comply with the Acts and the Regulations relative to Nondiscrimination in Federally-assisted programs of the U.S. Department of Transportation, Federal Highway Administration (FHWA), as they may be amended from time to time, which are herein incorporated by reference and made a part of this contract.

(b) Nondiscrimination

The contractor, with regard to the work performed by it during the contract, shall not discriminate on the grounds of race, color, or national origin in the selection and retention of subcontractors, including procurements of materials and leases of equipment. The contractor shall not participate directly or indirectly in the discrimination prohibited by the Acts and the Regulations, including employment practices when the contract covers any activity, project, or program set forth in Appendix B of 49 CFR Part 21.

(c) Solicitations for Subcontractors, Including Procurements of Materials and Equipment

In all solicitations, either by competitive bidding, or negotiation made by the contractor for work to be performed under a subcontract, including procurements of materials, or leases of equipment, each potential subcontractor or supplier shall be notified by the contractor of the contractor's obligations under this contract and the Acts and the Regulations relative to Nondiscrimination on the grounds of race, color, or national origin.

(d) Information and Reports

The contractor shall provide all information and reports required by the Acts, the Regulations, and directives issued pursuant thereto and shall permit access to its books,

records, accounts, other sources of information, and its facilities as may be determined by the Recipient or the FHWA to be pertinent to ascertain compliance with such Acts, Regulations, and instructions. Where any information required of a contractor is in the exclusive possession of another who fails or refuses to furnish the information, the contractor shall so certify to the Recipient or the FHWA, as appropriate, and shall set forth what efforts it has made to obtain the information.

(e) Sanctions for Noncompliance:

In the event of a contractor's noncompliance with the Non-discrimination provisions of this contract, the Recipient will impose such contract sanctions as it and/or the FHWA may determine to be appropriate, including, but not limited to:

- (i) Withholding payments to the contractor under the contract until the contractor complies; and/or
- (ii) Cancelling, terminating, or suspending a contract, in whole or in part.

(f) Incorporation of Provisions

The contractor shall include the provisions of paragraphs (a) through (f) in every subcontract, including procurements of materials and leases of equipment, unless exempt by the Acts, the Regulations and directives issued pursuant thereto. The contractor shall take action with respect to any subcontract or procurement as the Recipient or the FHWA may direct as a means of enforcing such provisions including sanctions for noncompliance. Provided, that if the contractor becomes involved in, or is threatened with litigation by a subcontractor, or supplier because of such direction, the contractor may request the Recipient to enter into any litigation to protect the interests of the Recipient. In addition, the contractor may request the United States to enter into the litigation to protect the interests of the United States.

(2) Title VI Nondiscrimination Program (23 CFR 200.5(p))

The North Carolina Department of Transportation (NCDOT) has assured the USDOT that, as a condition to receiving federal financial assistance, NCDOT will comply with Title VI of the Civil Rights Act of 1964 and all requirements imposed by Title 49 CFR part 21 and related nondiscrimination authorities to ensure that no person shall, on the ground of race, color, national origin, limited English proficiency, sex, age, or disability (including religion/creed or income-level, where applicable), be excluded from participation in, be denied the benefits of, or be subjected to discrimination under any programs, activities, or services conducted or funded by NCDOT. Contractors and other organizations under contract or agreement with NCDOT must also comply with Title VI and related authorities, therefore:

- (a) During the performance of this contract or agreement, contractors (e.g., subcontractors, consultants, vendors, prime contractors) are responsible for complying with NCDOT's Title VI Program. Contractors are not required to prepare or submit Title VI Programs. To comply with this section, the prime contractor shall:
 - 1. Post NCDOT's Notice of Nondiscrimination and the Contractor's own Equal Employment Opportunity (EEO) Policy in conspicuous locations accessible to all employees, applicants and subcontractors on the jobsite.

2. Physically incorporate the required Title VI clauses into all subcontracts on federally-assisted and state-funded NCDOT projects, and ensure inclusion by subcontractors into all lower-tier subcontracts.
 3. Required Solicitation Language. The Contractor shall include the following notification in all solicitations for bids and requests for work or material, regardless of funding source:

“The North Carolina Department of Transportation, in accordance with the provisions of Title VI of the Civil Rights Act of 1964 (78 Stat. 252, 42 U.S.C. §§ 2000d to 2000d-4) and the Regulations, hereby notifies all bidders that it will affirmatively ensure that any contract entered into pursuant to this advertisement, disadvantaged business enterprises will be afforded full and fair opportunity to submit bids in response to this invitation and will not be discriminated against on the grounds of race, color, or national origin in consideration for an award. In accordance with other related nondiscrimination authorities, bidders and contractors will also not be discriminated against on the grounds of sex, age, disability, low-income level, creed/religion, or limited English proficiency in consideration for an award.”
 4. Physically incorporate the FHWA-1273, in its entirety, into all subcontracts and subsequent lower tier subcontracts on Federal-aid highway construction contracts only.
 5. Provide language assistance services (i.e., written translation and oral interpretation), free of charge, to LEP employees and applicants. Contact NCDOT OCR for further assistance, if needed.
 6. For assistance with these Title VI requirements, contact the NCDOT Title VI Nondiscrimination Program at 1-800-522-0453.
- (b) Subrecipients (e.g. cities, counties, LGAs, planning organizations) may be required to prepare and submit a Title VI Plan to NCDOT, including Title VI Assurances and/or agreements. Subrecipients must also ensure compliance by their contractors and subrecipients with Title VI. (23 CFR 200.9(b)(7))
- (c) If reviewed or investigated by NCDOT, the contractor or subrecipient agrees to take affirmative action to correct any deficiencies found within a reasonable time period, not to exceed 90 calendar days, unless additional time is granted by NCDOT. (23 CFR 200.9(b)(15))
- (d) The Contractor is responsible for notifying subcontractors of NCDOT’s External Discrimination Complaints Process.
1. Applicability

Title VI and related laws protect participants and beneficiaries (e.g., members of the public and contractors) from discrimination by NCDOT employees, subrecipients and contractors, regardless of funding source.

2. Eligibility

Any person—or class of persons—who believes he/she has been subjected to discrimination based on race, color, national origin, Limited English Proficiency (LEP), sex, age, or disability (and religion in the context of employment, aviation, or transit) may file a written complaint. The law also prohibits intimidation or retaliation of any sort.

3. Time Limits and Filing Options

Complaints may be filed by the affected individual(s) or a representative and must be filed no later than 180 calendar days after the following:

- (i) The date of the alleged act of discrimination; or
- (ii) The date when the person(s) became aware of the alleged discrimination; or
- (iii) Where there has been a continuing course of conduct, the date on which that conduct was discontinued or the latest instance of the conduct.

Title VI and related discrimination complaints may be submitted to the following entities:

- North Carolina Department of Transportation, Office of Civil Rights, Title VI Program, 1511 Mail Service Center, Raleigh, NC 27699-1511; toll free 1-800-522-0453
- Federal Highway Administration, North Carolina Division Office, 310 New Bern Avenue, Suite 410, Raleigh, NC 27601, 919-747-7010
- US Department of Transportation, Departmental Office of Civil Rights, External Civil Rights Programs Division, 1200 New Jersey Avenue, SE, Washington, DC 20590; 202-366-4070

4. Format for Complaints

Complaints must be in writing and signed by the complainant(s) or a representative, and include the complainant's name, address, and telephone number. Complaints received by fax or e-mail will be acknowledged and processed. Allegations received by telephone will be reduced to writing and provided to the complainant for confirmation or revision before processing. Complaints will be accepted in other languages, including Braille.

5. Discrimination Complaint Form

Contact NCDOT Civil Rights to receive a full copy of the Discrimination Complaint Form and procedures.

6. Complaint Basis

Allegations must be based on issues involving race, color, national origin (LEP), sex, age, disability, or religion (in the context of employment, aviation or transit). "Basis" refers to the complainant's membership in a protected group category.

**TABLE 103-1
COMPLAINT BASIS**

Protected Categories	Definition	Examples	Applicable Nondiscrimination Authorities
Race and Ethnicity	An individual belonging to one of the accepted racial groups; or the perception, based usually on physical characteristics that a person is a member of a racial group	Black/African American, Hispanic/Latino, Asian, American Indian/Alaska Native, Native Hawaiian/Pacific Islander, White	Title VI of the Civil Rights Act of 1964; 49 CFR Part 21; 23 CFR 200; 49 U.S.C. 5332(b); 49 U.S.C. 47123. <i>(Executive Order 13166)</i>
Color	Color of skin, including shade of skin within a racial group	Black, White, brown, yellow, etc.	
National Origin <i>(Limited English Proficiency)</i>	Place of birth. Citizenship is not a factor. <i>(Discrimination based on language or a person's accent is also covered)</i>	Mexican, Cuban, Japanese, Vietnamese, Chinese	
Sex	Gender. The sex of an individual. <i>Note: Sex under this program does not include sexual orientation.</i>	Women and Men	1973 Federal-Aid Highway Act; 49 U.S.C. 5332(b); 49 U.S.C. 47123.
Age	Persons of any age	21-year-old person	Age Discrimination Act of 1975 49 U.S.C. 5332(b); 49 U.S.C. 47123.
Disability	Physical or mental impairment, permanent or temporary, or perceived.	Blind, alcoholic, para-amputee, epileptic, diabetic, arthritic	Section 504 of the Rehabilitation Act of 1973; Americans with Disabilities Act of 1990
Religion (in the context of employment) <i>(Religion/ Creed in all aspects of any aviation or transit-related construction)</i>	An individual belonging to a religious group; or the perception, based on distinguishable characteristics that a person is a member of a religious group. In practice, actions taken as a result of the moral and ethical beliefs as to what is right and wrong, which are sincerely held with the strength of traditional religious views. <i>Note: Does not have to be associated with a recognized religious group or church; if an individual sincerely holds to the belief, it is a protected religious practice.</i>	Muslim, Christian, Sikh, Hindu, etc.	Title VII of the Civil Rights Act of 1964; 23 CFR 230; FHWA-1273 Required Contract Provisions. <i>(49 U.S.C. 5332(b); 49 U.S.C. 47123)</i>

(3) Pertinent Nondiscrimination Authorities

During the performance of this contract, the contractor, for itself, its assignees, and successors in interest agrees to comply with the following non-discrimination statutes and authorities, including, but not limited to:

- (a) Title VI of the Civil Rights Act of 1964 (42 U.S.C. § 2000d et seq., 78 stat. 252), (prohibits discrimination on the basis of race, color, national origin); and 49 CFR Part 21.

- (b) The Uniform Relocation Assistance and Real Property Acquisition Policies Act of 1970, (42 U.S.C. § 4601), (prohibits unfair treatment of persons displaced or whose property has been acquired because of Federal or Federal-aid programs and projects);
- (c) Federal-Aid Highway Act of 1973, (23 U.S.C. § 324 et seq.), (prohibits discrimination on the basis of sex);
- (d) Section 504 of the Rehabilitation Act of 1973, (29 U.S.C. § 794 et seq.), as amended, (prohibits discrimination on the basis of disability) and 49 CFR Part 27;
- (e) The Age Discrimination Act of 1975, as amended, (42 U.S.C. § 6101 et seq.), (prohibits discrimination on the basis of age);
- (f) Airport and Airway Improvement Act of 1982, (49 USC § 471, Section 47123), as amended, (prohibits discrimination based on race, creed, color, national origin, or sex);
- (g) The Civil Rights Restoration Act of 1987, (PL 100-209), (Broadened the scope, coverage and applicability of Title VI of the Civil Rights Act of 1964, The Age Discrimination Act of 1975 and Section 504 of the Rehabilitation Act of 1973, by expanding the definition of the terms "programs or activities" to include all of the programs or activities of the Federal-aid recipients, sub-recipients and contractors, whether such programs or activities are Federally funded or not);
- (h) Titles II and III of the Americans with Disabilities Act, which prohibit discrimination on the basis of disability in the operation of public entities, public and private transportation systems, places of public accommodation, and certain testing entities (42 U.S.C. §§ 12131-12189) as implemented by Department of Transportation regulations at 49 C.F.R. parts 37 and 38;
- (i) The Federal Aviation Administration's Nondiscrimination statute (49 U.S.C. § 47123) (prohibits discrimination on the basis of race, color, national origin, and sex);
- (j) Executive Order 12898, Federal Actions to Address Environmental Justice in Minority Populations and Low-Income Populations, which ensures Nondiscrimination against minority populations by discouraging programs, policies, and activities with disproportionately high and adverse human health or environmental effects on minority and low-income populations;
- (k) Executive Order 13166, Improving Access to Services for Persons with Limited English Proficiency, and resulting agency guidance, national origin discrimination includes discrimination because of Limited English proficiency (LEP). To ensure compliance with Title VI, you must take reasonable steps to ensure that LEP persons have meaningful access to your programs (70 Fed. Reg. at 74087 to 74100);
- (l) Title IX of the Education Amendments of 1972, as amended, which prohibits you from discriminating because of sex in education programs or activities (20 U.S.C. 1681 et seq).
- (m) Title VII of the Civil Rights Act of 1964 (42 U.S.C. § 2000e et seq., Pub. L. 88-352), (prohibits employment discrimination on the basis of race, color, religion, sex, or national origin).

(4) Additional Title VI Assurances

***The following Title VI Assurances (Appendices B, C and D) shall apply, as applicable*

- (a) Clauses for Deeds Transferring United States Property (1050.2A, Appendix B)

The following clauses will be included in deeds effecting or recording the transfer of real property, structures, or improvements thereon, or granting interest therein from the United States pursuant to the provisions of Assurance 4.

NOW, THEREFORE, the U.S. Department of Transportation as authorized by law and upon the condition that the North Carolina Department of Transportation (NCDOT) will accept title to the lands and maintain the project constructed thereon in accordance with the North Carolina General Assembly, the Regulations for the Administration of the Federal-Aid Highway Program, and the policies and procedures prescribed by the Federal Highway Administration of the U.S. Department of Transportation in accordance and in compliance with all requirements imposed by Title 49, Code of Federal Regulations, U.S. Department of Transportation, Subtitle A, Office of the Secretary, Part 21, Nondiscrimination in Federally-assisted programs of the U.S. Department of Transportation pertaining to and effectuating the provisions of Title VI of the Civil Rights Act of 1964 (78 Stat. 252; 42 U.S.C. § 2000d to 2000d-4), does hereby remise, release, quitclaim and convey unto the NCDOT all the right, title and interest of the U.S. Department of Transportation in and to said lands described in Exhibit A attached hereto and made a part hereof.

(HABENDUM CLAUSE)

TO HAVE AND TO HOLD said lands and interests therein unto the North Carolina Department of Transportation (NCDOT) and its successors forever, subject, however, to the covenants, conditions, restrictions and reservations herein contained as follows, which will remain in effect for the period during which the real property or structures are used for a purpose for which Federal financial assistance is extended or for another purpose involving the provision of similar services or benefits and will be binding on the NCDOT, its successors and assigns.

The NCDOT, in consideration of the conveyance of said lands and interests in lands, does hereby covenant and agree as a covenant running with the land for itself, its successors and assigns, that (1) no person will on the grounds of race, color, or national origin, be excluded from participation in, be denied the benefits of, or be otherwise subjected to discrimination with regard to any facility located wholly or in part on, over, or under such lands hereby conveyed [,] [and]* (2) that the NCDOT will use the lands and interests in lands and interests in lands so conveyed, in compliance with all requirements imposed by or pursuant to Title 49, Code of Federal Regulations, U.S. Department of Transportation, Subtitle A, Office of the Secretary, Part 21, Nondiscrimination in Federally-assisted programs of the U.S. Department of Transportation, Effectuation of Title VI of the Civil Rights Act of 1964, and as said Regulations and Acts may be amended [, and (3) that in the event of breach of any of the above-mentioned nondiscrimination conditions, the Department will have a right to enter or re-enter said lands and facilities on said land, and that above described land and facilities will thereon revert to and vest in and become the absolute property of the U.S. Department of Transportation and its assigns as such interest existed prior to this instruction].*

(*Reverter clause and related language to be used only when it is determined that such a clause is necessary in order to make clear the purpose of Title VI.)

(b) Clauses for Transfer of Real Property Acquired or Improved Under the Activity, Facility, or Program (1050.2A, Appendix C)

The following clauses will be included in deeds, licenses, leases, permits, or similar instruments entered into by the North Carolina Department of Transportation (NCDOT) pursuant to the provisions of Assurance 7(a):

1. The (grantee, lessee, permittee, etc. as appropriate) for himself/herself, his/her heirs, personal representatives, successors in interest, and assigns, as a part of the consideration hereof, does hereby covenant and agree [in the case of deeds and leases add "as a covenant running with the land"] that:
 - (i.) In the event facilities are constructed, maintained, or otherwise operated on the property described in this (deed, license, lease, permit, etc.) for a purpose for which a U.S. Department of Transportation activity, facility, or program is extended or for another purpose involving the provision of similar services or benefits, the (grantee, licensee, lessee, permittee, etc.) will maintain and operate such facilities and services in compliance with all requirements imposed by the Acts and Regulations (as may be amended) such that no person on the grounds of race, color, or national origin, will be excluded from participation in, denied the benefits of, or be otherwise subjected to discrimination in the use of said facilities.
2. With respect to licenses, leases, permits, etc., in the event of breach of any of the above Nondiscrimination covenants, the NCDOT will have the right to terminate the (lease, license, permit, etc.) and to enter, re-enter, and repossess said lands and facilities thereon, and hold the same as if the (lease, license, permit, etc.) had never been made or issued. *
3. With respect to a deed, in the event of breach of any of the above Nondiscrimination covenants, the NCDOT will have the right to enter or re-enter the lands and facilities thereon, and the above described lands and facilities will there upon revert to and vest in and become the absolute property of the NCDOT and its assigns. *

(*Reverter clause and related language to be used only when it is determined that such a clause is necessary to make clear the purpose of Title VI.)

(c) Clauses for Construction/Use/Access to Real Property Acquired Under the Activity, Facility or Program (1050.2A, Appendix D)

The following clauses will be included in deeds, licenses, permits, or similar instruments/ agreements entered into by the North Carolina Department of Transportation (NCDOT) pursuant to the provisions of Assurance 7(b):

1. The (grantee, licensee, permittee, etc., as appropriate) for himself/herself, his/her heirs, personal representatives, successors in interest, and assigns, as a part of the consideration hereof, does hereby covenant and agree (in the case of deeds and leases add, "as a covenant running with the land") that (1) no person on the ground of race, color, or national origin, will be excluded from participation in, denied the benefits of, or be otherwise subjected to discrimination in the use of said facilities, (2) that in the construction of any improvements on, over, or under such land, and the furnishing of services thereon, no person on the ground of race, color, or national origin, will be excluded from participation in, denied the benefits of, or otherwise be subjected to discrimination, (3) that the (grantee, licensee, lessee, permittee, etc.) will use the premises in compliance with all other requirements imposed by or pursuant to the Acts and Regulations, as amended, set forth in this Assurance.
2. With respect to (licenses, leases, permits, etc.), in the event of breach of any of the above Non-discrimination covenants, the NCDOT will have the right to terminate the (license, permit, etc., as appropriate) and to enter or re-enter and repossess said land and the facilities thereon, and hold the same as if said (license, permit, etc., as appropriate) had never been made or issued. *
3. With respect to deeds, in the event of breach of any of the above Nondiscrimination covenants, the NCDOT will there upon revert to and vest in and become the absolute property of the NCDOT and its assigns. *

(*Reverter clause and related language to be used only when it is determined that such a clause is necessary to make clear the purpose of Title VI.)

STANDARD SPECIAL PROVISION**ON-THE-JOB TRAINING**

(10-16-07)(Rev. 4-21-15)

Z-10

Description

The North Carolina Department of Transportation will administer a custom version of the Federal On-the-Job Training (OJT) Program, commonly referred to as the Alternate OJT Program. All contractors (existing and newcomers) will be automatically placed in the Alternate Program. Standard OJT requirements typically associated with individual projects will no longer be applied at the project level. Instead, these requirements will be applicable on an annual basis for each contractor administered by the OJT Program Manager.

On the Job Training shall meet the requirements of 23 CFR 230.107 (b), 23 USC – Section 140, this provision and the On-the-Job Training Program Manual.

The Alternate OJT Program will allow a contractor to train employees on Federal, State and privately funded projects located in North Carolina. However, priority shall be given to training employees on NCDOT Federal-Aid funded projects.

Minorities and Women

Developing, training and upgrading of minorities and women toward journeyman level status is a primary objective of this special training provision. Accordingly, the Contractor shall make every effort to enroll minority and women as trainees to the extent that such persons are available within a reasonable area of recruitment. This training commitment is not intended, and shall not be used, to discriminate against any applicant for training, whether a member of a minority group or not.

Assigning Training Goals

The Department, through the OJT Program Manager, will assign training goals for a calendar year based on the contractors' past three years' activity and the contractors' anticipated upcoming year's activity with the Department. At the beginning of each year, all contractors eligible will be contacted by the Department to determine the number of trainees that will be assigned for the upcoming calendar year. At that time the Contractor shall enter into an agreement with the Department to provide a self-imposed on-the-job training program for the calendar year. This agreement will include a specific number of annual training goals agreed to by both parties. The number of training assignments may range from 1 to 15 per contractor per calendar year. The Contractor shall sign an agreement to fulfill their annual goal for the year.\

Training Classifications

The Contractor shall provide on-the-job training aimed at developing full journeyman level workers in the construction craft/operator positions. Preference shall be given to providing training in the following skilled work classifications:

Equipment Operators	Office Engineers
Truck Drivers	Estimators
Carpenters	Iron / Reinforcing Steel Workers
Concrete Finishers	Mechanics
Pipe Layers	Welders

The Department has established common training classifications and their respective training requirements that may be used by the contractors. However, the classifications established are not all-inclusive. Where the training is oriented toward construction applications, training will be allowed in lower-level management positions such as office engineers and estimators. Contractors shall submit new classifications for specific job functions that their employees are performing. The Department will review and recommend for acceptance to FHWA the new classifications proposed by contractors, if applicable. New classifications shall meet the following requirements:

Proposed training classifications are reasonable and realistic based on the job skill classification needs, and

The number of training hours specified in the training classification is consistent with common practices and provides enough time for the trainee to obtain journeyman level status.

The Contractor may allow trainees to be trained by a subcontractor provided that the Contractor retains primary responsibility for meeting the training and this provision is made applicable to the subcontract. However, only the Contractor will receive credit towards the annual goal for the trainee.

Where feasible, 25 percent of apprentices or trainees in each occupation shall be in their first year of apprenticeship or training. The number of trainees shall be distributed among the work classifications on the basis of the contractor's needs and the availability of journeymen in the various classifications within a reasonable area of recruitment.

No employee shall be employed as a trainee in any classification in which they have successfully completed a training course leading to journeyman level status or in which they have been employed as a journeyman.

Records and Reports

The Contractor shall maintain enrollment, monthly and completion reports documenting company compliance under these contract documents. These documents and any other information as requested shall be submitted to the OJT Program Manager.

Upon completion and graduation of the program, the Contractor shall provide each trainee with a certification Certificate showing the type and length of training satisfactorily completed.

Trainee Interviews

All trainees enrolled in the program will receive an initial and Trainee/Post graduate interview conducted by the OJT program staff.

Trainee Wages

Contractors shall compensate trainees on a graduating pay scale based upon a percentage of the prevailing minimum journeyman wages (Davis-Bacon Act). Minimum pay shall be as follows:

60 percent	of the journeyman wage for the first half of the training period
75 percent	of the journeyman wage for the third quarter of the training period
90 percent	of the journeyman wage for the last quarter of the training period

In no instance shall a trainee be paid less than the local minimum wage. The Contractor shall adhere to the minimum hourly wage rate that will satisfy both the NC Department of Labor (NCDOL) and the Department.

Achieving or Failing to Meet Training Goals

The Contractor will be credited for each trainee employed by him on the contract work who is currently enrolled or becomes enrolled in an approved program and who receives training for at least 50 percent of the specific program requirement. Trainees will be allowed to be transferred between projects if required by the Contractor's scheduled workload to meet training goals.

If a contractor fails to attain their training assignments for the calendar year, they may be taken off the NCDOT's Bidders List.

Measurement and Payment

No compensation will be made for providing required training in accordance with these contract documents.

TEMPORARY TRAFFIC CONTROL

(9/1/2021) (Rev. 10/13/2023)

General Requirements

Maintain traffic on all roads in accordance with Divisions 10, 11 and 12 of the *NCDOT Standard Specifications* and the following provisions:

Install Work Zone Advance Warning Signs when work is within 40 ft. from the edge of the travel lane in accordance with Standard Drawing No. 1101.01 of the *NCDOT Roadway Standard Drawings* prior to beginning any other work. If signs are installed more than 3 calendar days prior to the beginning of work, cover the signs until the work begins. Install each work zone advance warning sign separately and not on the same post or stand with any other sign.

When personnel and/or equipment are working within 15 ft. of an open travel lane, close the nearest open shoulder using Roadway Standard Drawing No. 1101.04 unless the work area is protected by barrier or guardrail, or a lane closure is installed.

When personnel and/or equipment are working on the shoulder adjacent to an undivided facility and within 5 ft. of an open travel lane, close the nearest open travel lane using Roadway Standard Drawing No. 1101.02 of the *NCDOT Roadway Standard Drawings* unless the work area is protected by barrier or guardrail.

When personnel and/or equipment are working on the shoulder adjacent to a divided facility and within 10 ft. of an open travel lane, close the nearest open travel lane using Roadway Standard Drawing No. 1101.02 of the *NCDOT Roadway Standard Drawings*, unless the work area is protected by barrier or guardrail.

When personnel and/or equipment are working within a lane of travel of an undivided or divided facility, close the lane using Roadway Standard Drawing No. 1101.02 of the *NCDOT Roadway Standard Drawings* or as directed by the Engineer. Conduct the work so that all personnel and/or equipment remain within the closed travel lane. Perform work only when weather and visibility conditions allow safe operations as directed by the Engineer.

Do not work simultaneously within 15 ft. on both sides of an open travel way, ramp, or loop within the same location, unless protected with guardrail or barrier.

Remove lane closure devices from the lane when work is not being performed behind the lane closure or when a lane closure is no longer needed or as directed by the Engineer.

Temporary Traffic Control (TTC)

Refer to Standard Drawing No. 1101.02, 1101.03, 1101.04, 1101.11, 1110.01, 1110.02, 1115.01, 1130.01, 1135.01, 1145.01, 1150.01, 1165.01, and 1180.01 of the *NCDOT Roadway Standard Drawings* when closing a lane of travel or shoulder in the work zone.

Notify the Engineer (30) calendar days prior to any traffic pattern alteration.

Ensure all necessary signing is in place prior to altering any traffic pattern.

When lane closures are not in effect, space channelizing devices in work areas no greater in feet than twice the posted speed limit (MPH), except 10 ft. on-center in radii, and 3 ft. off the edge of an open travelway. Refer to *NCDOT Standard Specifications* Sections 1130 (Drums), 1135 (Cones), and 1180 (Skinny Drums) for additional requirements.

Place additional sets of three channelizing devices (Drums, Cones, or Skinny Drums) perpendicular to the edge of travelway on 100 to 500 ft. centers, as directed by the Engineer, when unopened lanes are closed to traffic.

Place Type III Barricades with “ROAD CLOSED” sign R11-2 attached, of sufficient length to close the entire roadway.

Install black on orange “DIP” (W8-2) and/or “BUMP” (W8-1) signs in advance of the uneven area in accordance with Roadway Standard Drawing 1101.11, or as directed by the Engineer.

Law Enforcement

Use uniformed Law Enforcement officers to control traffic at signalized intersections when the temporary traffic pattern cannot be controlled by the signal’s normal operation.

Project Requirements

Failure to comply with the following requirements will result in a suspension of all other operations:

1. Prior to beginning work, the Contractor shall submit a written construction sequence for traffic control and construction lighting to the Engineer at the first pre-construction meeting and the sequence must be approved before closing a lane of traffic.
2. Obtain written approval of the Engineer before working in more than one location or setting up additional lane closures. The maximum length of any one lane closure is 1 mile unless otherwise directed by the Engineer.
3. If Lane Closure Restrictions apply, see Special Provision, “Intermediate Contract Times and Liquidated Damages”.
4. Contractor shall conduct operations in an order such that water does not accumulate.

5. The Contractor on this and any adjacent projects, or subcontractors working within this
6. project shall coordinate lane closure location, type, and direction with the Engineer to best
7. maintain lane continuity through the limits of this and adjacent projects.
8. Operate equipment and conduct operations in the same direction as the flow of traffic unless the operation is protected by barrier or guardrail or as directed by the Engineer. Maintain vehicular access in accordance with Section 1101-05 of the NCDOT Standard Specifications.
9. Provide appropriate construction lighting in accordance with Section 1413 of the NCDOT Standard Specifications.

Measurement and Payment

No separate payment will be made for Temporary Traffic Control (Incidental) as the work is considered incidental to the other contract items.

Temporary Traffic Control (Incidental) shall include but not be limited to providing Signs (portable, stationary, and/or barricade mounted), including detour signing, Truck Mounted Attenuators (TMA), Portable Changeable Message Signs (PCMS), Flashing Arrow Boards (FAB), Pilot Vehicle, Flaggers, Cones, Skinny Drums and Drums as shown in the applicable Roadway Standard Drawings and all labor, tools, equipment and incidentals necessary to furnish, install, maintain and remove traffic control devices when no longer required.

Temporary Traffic Control (Incidental) does not include Portable Concrete Barrier, Waterfilled Barrier, Temporary Crash Cushions, Digital Speed Limit Signs, Sequential Flashing Lights, or Presence Lights as these devices are beyond the scope of this provision.

ADDENDA

ADDENDUM #1

I, _____
(SIGNATURE)

representing _____

Acknowledge receipt of Addendum #1.

ADDENDUM #2

I, _____
(SIGNATURE)

representing _____

Acknowledge receipt of Addendum #2.

ADDENDUM #3

I, _____
(SIGNATURE)

representing _____

Acknowledge receipt of Addendum #3.

AWARD LIMITS ON MULTIPLE PROJECTS

It is the desire of the Proposer to be awarded contracts, the value of which will not exceed a total of \$ _____, for those projects indicated below on which bids are being opened on the same date as shown in the Proposal Form. Individual projects shall be indicated by placing the project number and county in the appropriate place below. Projects not selected will not be subject to an award limit.

(Project Number)

(County)

(Project Number)

(County)

(Project Number)

(County)

(Project Number)

(County)

*If a Proposer desires to limit the total amount of work awarded to him in this letting, he shall state such limit in the space provided above in the second line of this form.

It is agreed that in the event that I am (we are) the successful bidder on indicated projects, the total value of which is more that the above stipulated award limits, the Board of Transportation will award me (us) projects from among those indicated which have a total value not exceeding the award limit and which will result in the best advantage to the Department of Transportation.

**Signature of Authorized Person

**Only those persons authorized to sign bids under Subarticle 102-8(A)(12) shall be authorized to sign this form.

NON-COLLUSION, DEBARMENT AND GIFT BAN CERTIFICATION

CORPORATION

The prequalified bidder being duly sworn, solemnly swears (or affirms) that neither he, nor any official, agent or employee has entered into any agreement, participated in any collusion, or otherwise taken any action which is in restraint of free competitive bidding in connection with any bid or contract, that the prequalified bidder has not been convicted of violating N.C.G.S. §133-24 within the last three years, and that the prequalified bidder intends to do the work with his own bona fide employees or subcontractors and will not bid for the benefit of another contractor.

By submitting this non-collusion, debarment and gift ban certification, the Contractor is attesting his status under penalty of perjury under the laws of the United States in accordance with the Debarment Certification attached, provided that the Debarment Certification also includes any required statements concerning exceptions that are applicable.

N.C.G.S. §133-32 and Executive Order 24 prohibit the offer to, or acceptance by, any State Employee of any gift from anyone with a contract with the State, or from any person seeking to do business with the State. By execution of any response in this procurement, you attest, for your entire organization and its employees or agents, that you are not aware that any such gift has been offered, accepted, or promised by any employees of your organization.

SIGNATURE OF PREQUALIFIED BIDDER

Full name of Corporation

Address as Prequalified

Attest _____
Secretary/Assistant Secretary
(Select appropriate title)

By _____
President/Vice President/Assistant Vice President
(Select appropriate title)

Print or Type Signer's name

Print or Type Signer's name



NON-COLLUSION, DEBARMENT AND GIFT BAN CERTIFICATION

PARTNERSHIP

The prequalified bidder, being duly sworn, solemnly swears (or affirms) that neither he, nor any official, agent or employee has entered into any agreement, participated in any collusion, or otherwise taken any action which is in restraint of free competitive bidding in connection with any bid or contract, that the prequalified bidder has not been convicted of violating *N.C.G.S. § 133-24* within the last three years, and that the prequalified bidder intends to do the work with its own bona fide employees or subcontractors and will not bid for the benefit of another contractor.

By submitting this non-collusion, debarment and gift ban certification, the Contractor is attesting his status under penalty of perjury under the laws of the United States in accordance with the Debarment Certification attached, provided that the Debarment Certification also includes any required statements concerning exceptions that are applicable.

N.C.G.S. § 133-32 and Executive Order 24 prohibit the offer to, or acceptance by, any State Employee of any gift from anyone with a contract with the State, or from any person seeking to do business with the State. By execution of any response in this procurement, you attest, for your entire organization and its employees or agents, that you are not aware that any such gift has been offered, accepted, or promised by any employees of your organization.

SIGNATURE OF PREQUALIFIED BIDDER

Full Name of
Partnership

Address as
Prequalified

Signature of Witness

Signature of Partner

Print or Type Signer's Name

Print or Type Signer's Name

**NON-COLLUSION, DEBARMENT AND GIFT BAN CERTIFICATION
LIMITED LIABILITY COMPANY**

The prequalified bidder, being duly sworn, solemnly swears (or affirms) that neither he, nor any official, agent or employee has entered into any agreement, participated in any collusion, or otherwise taken any action which is in restraint of free competitive bidding in connection with any bid or contract, that the prequalified bidder has not been convicted of violating *N.C.G.S. § 133-24* within the last three years, and that the prequalified bidder intends to do the work with its own bona fide employees or subcontractors and will not bid for the benefit of another contractor.

By submitting this non-collusion, debarment and gift ban certification, the Contractor is attesting his status under penalty of perjury under the laws of the United States in accordance with the Debarment Certification attached, provided that the Debarment Certification also includes any required statements concerning exceptions that are applicable.

N.C.G.S. § 133-32 and Executive Order 24 prohibit the offer to, or acceptance by, any State Employee of any gift from anyone with a contract with the State, or from any person seeking to do business with the State. By execution of any response in this procurement, you attest, for your entire organization and its employees or agents, that you are not aware that any such gift has been offered, accepted, or promised by any employees of your organization.

SIGNATURE OF PREQUALIFIED BIDDER

Full Name of Firm

Address as Prequalified

Signature of Witness

Signature of Member/Manager/Authorized Agent
(Select appropriate Title)

Print or Type Signer's Name

Print or Type Signer's Name

NON-COLLUSION, DEBARMENT AND GIFT BAN CERTIFICATION

JOINT VENTURE (2) or (3)

The prequalified bidder, being duly sworn, solemnly swears (or affirms) that neither he, nor any official, agent or employee has entered into any agreement, participated in any collusion, or otherwise taken any action which is in restraint of free competitive bidding in connection with any bid or contract, that the prequalified bidder has not been convicted of violating *N.C.G.S. § 133-24* within the last three years, and that the prequalified bidder intends to do the work with its own bona fide employees or subcontractors and will not bid for the benefit of another contractor.

By submitting this non-collusion, debarment and gift ban certification, the Contractor is attesting his status under penalty of perjury under the laws of the United States in accordance with the Debarment Certification attached, provided that the Debarment Certification also includes any required statements concerning exceptions that are applicable.

N.C.G.S. § 133-32 and Executive Order 24 prohibit the offer to, or acceptance by, any State Employee of any gift from anyone with a contract with the State, or from any person seeking to do business with the State. By execution of any response in this procurement, you attest, for your entire organization and its employees or agents, that you are not aware that any such gift has been offered, accepted, or promised by any employees of your organization.

SIGNATURE OF PREQUALIFIED BIDDER

Instructions: **2 Joint Venturers** Fill in lines (1), (2) and (3) and execute. **3 Joint Venturers** Fill in lines (1), (2), (3) and (4) and execute. On Line (1), fill in the name of the Joint Venture Company. On Line (2), fill in the name of one of the joint venturers and execute below in the appropriate manner. On Line (3), print or type the name of the other joint venturer and execute below in the appropriate manner. On Line (4), fill in the name of the third joint venturer, if applicable and execute below in the appropriate manner.

(1) _____
Name of Joint Venture

(2) _____
Name of Contractor

Address as Prequalified

BY

Signature of Witness or Attest

Signature of Contractor

Print or Type Signer's Name
If Corporation, affix Corporate Seal

AND

Print or Type Signer's Name

(3) _____
Name of Contractor

Address as Prequalified

BY

Signature of Witness or Attest

Signature of Contractor

Print or Type Signer's Name
If Corporation, affix Corporate Seal

AND

Print or Type Signer's Name

(4) _____
Name of Contractor

Address as Prequalified

BY

Signature of Witness or Attest

Signature of Contractor

Print or Type Signer's Name
If Corporation, affix Corporate Seal

Print or Type Signer's Name

CORPORATE SEAL(S)

NON-COLLUSION, DEBARMENT AND GIFT BAN CERTIFICATION

INDIVIDUAL DOING BUSINESS UNDER A FIRM NAME

The prequalified bidder, being duly sworn, solemnly swears (or affirms) that neither he, nor any official, agent or employee has entered into any agreement, participated in any collusion, or otherwise taken any action which is in restraint of free competitive bidding in connection with any bid or contract, that the prequalified bidder has not been convicted of violating *N.C.G.S. § 133-24* within the last three years, and that the prequalified bidder intends to do the work with its own bona fide employees or subcontractors and will not bid for the benefit of another contractor.

By submitting this non-collusion, debarment and gift ban certification, the Contractor is attesting his status under penalty of perjury under the laws of the United States in accordance with the Debarment Certification attached, provided that the Debarment Certification also includes any required statements concerning exceptions that are applicable.

N.C.G.S. § 133-32 and Executive Order 24 prohibit the offer to, or acceptance by, any State Employee of any gift from anyone with a contract with the State, or from any person seeking to do business with the State. By execution of any response in this procurement, you attest, for your entire organization and its employees or agents, that you are not aware that any such gift has been offered, accepted, or promised by any employees of your organization.

SIGNATURE OF PREQUALIFIED BIDDER

Name of Prequalified Bidder

Individual Name

Trading and Doing Business As

Full name of Firm

Address as Prequalified

Signature of Witness

Signature of Prequalified Bidder, Individual

Print or Type Signer's Name

Print or Type Signer's Name

NON-COLLUSION, DEBARMENT GIFT BAN CERTIFICATION

INDIVIDUAL DOING BUSINESS IN HIS OWN NAME

The prequalified bidder, being duly sworn, solemnly swears (or affirms) that neither he, nor any official, agent or employee has entered into any agreement, participated in any collusion, or otherwise taken any action which is in restraint of free competitive bidding in connection with any bid or contract, that the prequalified bidder has not been convicted of violating *N.C.G.S. § 133-24* within the last three years, and that the prequalified bidder intends to do the work with its own bona fide employees or subcontractors and will not bid for the benefit of another contractor.

By submitting this non-collusion, debarment and gift ban certification, the Contractor is attesting his status under penalty of perjury under the laws of the United States in accordance with the Debarment Certification attached, provided that the Debarment Certification also includes any required statements concerning exceptions that are applicable.

N.C.G.S. § 133-32 and Executive Order 24 prohibit the offer to, or acceptance by, any State Employee of any gift from anyone with a contract with the State, or from any person seeking to do business with the State. By execution of any response in this procurement, you attest, for your entire organization and its employees or agents, that you are not aware that any such gift has been offered, accepted, or promised by any employees of your organization.

SIGNATURE OF PREQUALIFIED BIDDER

Name of Prequalified Bidder _____
Print or Type Name

Address as Prequalified

Signature of Prequalified Bidder, Individually

Print or Type Signer's Name

Signature of Witness

Print or Type Signer's name

DEBARMENT CERTIFICATION

Conditions for certification:

1. The prequalified bidder shall provide immediate written notice to the Department if at any time the bidder learns that his certification was erroneous when he submitted his debarment certification or explanation that is file with the Department, or has become erroneous because of changed circumstances.
2. The terms *covered transaction, debarred, suspended, ineligible, lower tier covered transaction, participant, person, primary covered transaction, principal, proposal, and voluntarily excluded*, as used in this provision, have the meanings set out in the Definitions and Coverage sections of the rules implementing Executive Order 12549. A copy of the Federal Rules requiring this certification and detailing the definitions and coverages may be obtained from the Contract Officer of the Department.
3. The prequalified bidder agrees by submitting this form, that he will not knowingly enter into any lower tier covered transaction with a person who is debarred, suspended, declared ineligible, or voluntarily excluded from participation in NCDOT contracts, unless authorized by the Department.
4. For Federal Aid projects, the prequalified bidder further agrees that by submitting this form he will include the Federal-Aid Provision titled *Required Contract Provisions Federal-Aid Construction Contract (Form FHWA PR 1273)* provided by the Department, without subsequent modification, in all lower tier covered transactions.
5. The prequalified bidder may rely upon a certification of a participant in a lower tier covered transaction that he is not debarred, suspended, ineligible, or voluntarily excluded from the covered transaction, unless he knows that the certification is erroneous. The bidder may decide the method and frequency by which he will determine the eligibility of his subcontractors.
6. Nothing contained in the foregoing shall be construed to require establishment of a system of records in order to render in good faith the certification required by this provision. The knowledge and information of a participant is not required to exceed that which is normally possessed by a prudent person in the ordinary course of business dealings.
7. Except as authorized in paragraph 6 herein, the Department may terminate any contract if the bidder knowingly enters into a lower tier covered transaction with a person who is suspended, debarred, ineligible, or voluntarily excluded from participation in this transaction, in addition to other remedies available by the Federal Government.

DEBARMENT CERTIFICATION

The prequalified bidder certifies to the best of his knowledge and belief, that he and his principals:

- a. Are not presently debarred, suspended, proposed for debarment, declared ineligible, or voluntarily excluded from covered transactions by any Federal department or agency;
- b. Have not within a three-year period preceding this proposal been convicted of or had a civil judgment rendered against them for commission of fraud or a criminal offense in connection with obtaining, attempting to obtain, or performing a public (Federal, State or local) transaction or contract under a public transaction; violation of Federal or State antitrust statutes or commission of embezzlement, theft, forgery, bribery, falsification or destruction of records; making false statements; or receiving stolen property;
- c. Are not presently indicted for or otherwise criminally or civilly charged by a governmental entity (Federal, State or local) with commission of any of the offenses enumerated in paragraph b. of this certification; and
- d. Have not within a three-year period preceding this proposal had one or more public transactions (Federal, State or local) terminated for cause or default.
- e. Will submit a revised Debarment Certification immediately if his status changes and will show in his bid proposal an explanation for the change in status.

If the prequalified bidder cannot certify that he is not debarred, he shall provide an explanation with this submittal. An explanation will not necessarily result in denial of participation in a contract.

Failure to submit a non-collusion affidavit and debarment certification will result in the prequalified bidder's bid being considered non-responsive.

Check here if an explanation is attached to this certification.

**NORTH CAROLINA DEPARTMENT OF
TRANSPORTATION CONTRACT BID FORM
PURCHASE ORDER CONTRACT BID FORM**

CONTRACT ID #: D3POC0208

WBS ELEMENT: VARIOUS

COUNTIES: BRUNSWICK, DUPLIN, NEW HANOVER, PENDER,
ON SLOW, AND SAMPSON – DIVISION 3

TYPE OF WORK: LITTER/DEBRIS REMOVAL AND RECYCLING, ON
CALL (ID/IQ) ON INTERSTATE, PRIMARY AND
SECONDARY ROADS

LINE NO.	SEC NO.	ITEM NUMBER	ITEM DESCRIPTION	EST. QUANT.	UNIT	UNIT PRICE	AMOUNT BID
1	SP	611480000-N	Litter/Debris Removal and Recycling on Interstate Highways	100	SHM		
2	SP	611480000-N	Litter/Debris Removal and Recycling on Primary Divided Highways	250	SHM		
3	SP	611480000-N	Litter/Debris Removal and Recycling on Primary Undivided Highways	500	SHM		
4	SP	611480000-N	Litter/Debris Removal and Recycling on Secondary Divided Highways	100	SHM		
5	SP	611480000-N	Litter/Debris Removal and Recycling on Secondary Undivided Highways	1,000	SHM		
6	SP	613200000-N	Isolated Dump Sites (100 sqf)	10	EA		
7	SP	613200000-N	Isolated Bulk Items	50	EA		
8	SP	0000915000-N	Emergency Mobilization	5	EA		

TOTAL BID FOR PROJECT:

\$ _____

**THIS SECTION TO BE COMPLETED BY NORTH CAROLINA DEPARTMENT OF
TRANSPORTATION**

*This bid has been reviewed in accordance with Article 103-1 of the Standard Specifications for Roads
and Structures 2024.*

Reviewed by _____

_____ *(date)*

Accepted by NCDOT _____

_____ *(date)*

CONTRACTOR INFORMATION

Company Name

Contractor License Number:

Address:

Phone:

Email Address:

Name of individual authorized to answer questions concerning the information contained herein:

Name:

Telephone Number(s):

Email Address:
